

Physics 10154 - Exam #2a

Partial credit will be given provided you show all work and are solving parts of the problem correctly. Points will be deducted if you don't show your work (or if some parts are incorrect) even if you get the right answer. Clearly indicate your answer with a circle or box and remember to include correct units and significant figures.

(30 pts) A 2.5-kg mass is placed against a horizontal spring ($k = 550 \text{ N/m}$) that has been compressed 32 cm on a rough horizontal surface. The coefficient of kinetic friction between the mass and the surface is 0.18. When this system is released from rest, the spring launches the mass horizontally.

Once the spring reaches its equilibrium length, the mass is separated from the spring and continues to slide until coming to rest. What is the total horizontal distance the mass moves during this time (including the 32 cm while on the spring)?

2. (35 pts) A 3.1-kg book is initially at rest against a vertical wall. An applied force of 27 N acts on the book at an angle of 35° above the horizontal as shown. The coefficient of static friction is 0.44. The coefficient of kinetic friction is 0.29.

Does the book move? If no, find the magnitude and direction of the force of static friction acting on the book. If yes, find the magnitude and direction of the book's acceleration.

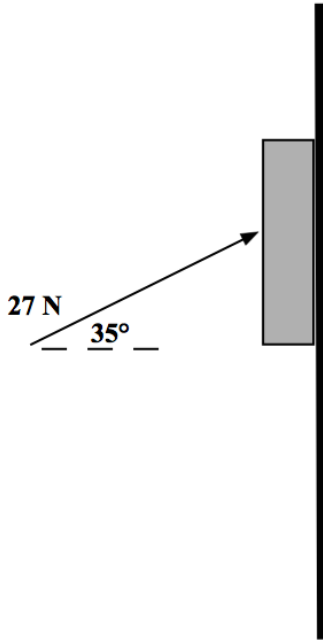

3. (35 pts) Block A (3.0 kg) is initially at rest on a frictionless, horizontal table. It is connected by a thin string over a pulley to a hanging block B (2.0 kg). Another string attached to block A provides a tension force of 8.0 N as shown. Once the system is set in motion, how much time does it take for block B to descend 55 cm to the floor below?

