

Physics 10154 - Exam #2d

Partial credit will be given provided you show all work and are solving parts of the problem correctly. Points will be deducted if you don't show your work (or if some parts are incorrect) even if you get the right answer. Clearly indicate your answer with a circle or box and remember to include correct units and significant figures.

1. (35 pts) A 3.50-kg mass is placed on a vertical spring ($k = 765 \text{ N/m}$) the is compressed by 65.0 cm. The system is released from rest, and the spring launched the mass upward to a maximum height of 3.85 meters above the initial position of the mass. How much work was done by frictional forces during this motion?

2. (30 pts) A 3.1-kg book is initially at rest against a vertical wall. An applied force of 27 N acts on the book at an angle of 35° above the horizontal as shown. The coefficient of static friction is 0.44. The coefficient of kinetic friction is 0.29.

Does the book move? If no, find the magnitude and direction of the force of static friction acting on the book. If yes, find the magnitude and direction of the book's acceleration.

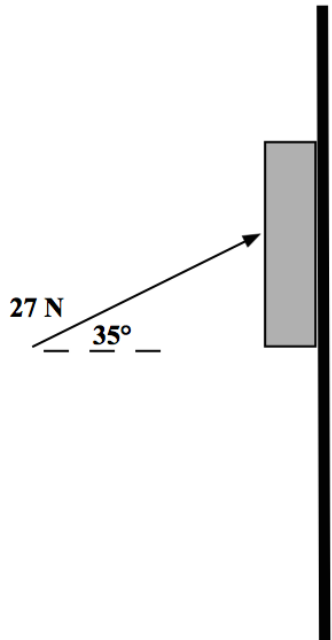

3. (35 pts) In the system below, mass A (4.5 kg) is hanging, and mass B (5.8 kg) is on the frictionless incline. They are connected over a pulley by a thin string and released from rest. How many seconds does it take for mass A to rise 72 cm?

