

# TROUBLESHOOTING

BROGA-03

## PROBLEM SYMPTOMS TABLE

Use the table below to help you find the cause of the problem. The numbers indicate the priority of the likely cause of the problem. Check each part in order. If necessary, replace these parts.

Symptom	Suspect Area	See page
Lower pedal or spongy pedal	1. Brake system (Fluid leaks)	-
	2. Brake system (Air in)	<a href="#">BR-5</a>
	3. Piston seals (Worn or damaged)	<a href="#">BR-28</a> <a href="#">BR-36</a> <a href="#">BR-48</a> <a href="#">BR-54</a>
	4. Master cylinder (Faulty)	<a href="#">BR-10</a>
	5. Booster push rod (Out of adjustment)	<a href="#">BR-21</a>
Brake drag	1. Brake pedal freeplay (Minimal)	<a href="#">BR-7</a>
	2. Parking brake lever travel (Out of adjustment)	<a href="#">BR-9</a>
	3. Parking brake wire (Sticking)	
	4. Parking brake shoe clearance (Out of adjustment)	<a href="#">BR-64</a>
	5. Pad (Cracked or distorted)	<a href="#">BR-22</a> <a href="#">BR-25</a> <a href="#">BR-42</a> <a href="#">BR-45</a>
	6. Piston (Stuck)	<a href="#">BR-28</a> <a href="#">BR-36</a> <a href="#">BR-48</a> <a href="#">BR-54</a>
	7. Piston (Frozen)	<a href="#">BR-28</a> <a href="#">BR-36</a> <a href="#">BR-48</a> <a href="#">BR-54</a>
	8. Tension or return spring (Faulty)	<a href="#">BR-60</a>
	9. Booster push rod (Out of adjustment)	<a href="#">BR-21</a>
	10. Vacuum leaks for booster system	<a href="#">BR-19</a>
	11. Master cylinder (Faulty)	<a href="#">BR-10</a>

BRAKE - TROUBLESHOOTING

<p>Brake pull</p>	<ol style="list-style-type: none"> <li>1. Piston (Stuck)</li> <li>2. Pad (Oily)</li> <li>3. Piston (Frozen)</li> <li>4. Disc (Scored)</li> <li>5. Pad (Cracked or distorted)</li> </ol>	<p>BR-28 BR-36 BR-48 BR-54 BR-22 BR-25 BR-42 BR-45 BR-28 BR-36 BR-48 BR-54 BR-28 BR-36 BR-48 BR-54 BR-22 BR-25 BR-42 BR-45</p>
<p>Hard pedal but brake inefficient</p>	<ol style="list-style-type: none"> <li>1. Brake system (Fluid leaks)</li> <li>2. Brake system (Air in)</li> <li>3. Piston (Stuck)</li> <li>4. Pad (Cracked or distorted)</li> <li>5. Pad (Oily)</li> <li>6. Pad (Glazed)</li> <li>7. Disc (Scored)</li> <li>8. Booster push rod (Out of adjustment)</li> <li>9. Vacuum leaks for booster system</li> </ol>	<p>- BR-5 BR-28 BR-36 BR-48 BR-54 BR-22 BR-25 BR-42 BR-45 BR-22 BR-25 BR-42 BR-45 BR-22 BR-25 BR-42 BR-45 BR-28 BR-36 BR-48 BR-54 BR-21 BR-19</p>

Symptom	Suspect Area	See page
Noise from brake	1. Pad (Cracked or distorted)	BR-22 BR-25 BR-42 BR-45
	2. Installation bolt (Loose)	BR-28 BR-36 BR-48 BR-54
	3. Disc (Scored)	BR-28 BR-36 BR-48 BR-54
	4. Pad support plate (Loose)	BR-22 BR-42
	5. Sliding pin (Worn)	BR-28 BR-48
	6. Pad (Dirty)	BR-22 BR-25 BR-42 BR-45
	7. Pad (Glazed)	BR-22 BR-25 BR-42 BR-45
	8. Tension or return spring (Faulty)	BR-60
	9. Anti-squeal shim (Damaged)	BR-22 BR-25 BR-42 BR-45
	10. Hold-down spring (Damaged)	BR-60

## BRAKE FLUID BLEEDING

BROGB-01

### HINT:

If any work is done on the brake system or if air in the brake lines is suspected, bleed the system of air.

### NOTICE:

**Do not let brake fluid remain on painted surfaces. Wash it off immediately.**

1. REMOVE RESERVOIR CAP
2. FILL RESERVOIR WITH BRAKE FLUID  
Fluid: SAE J1703 or FMVSS No.116DOT3

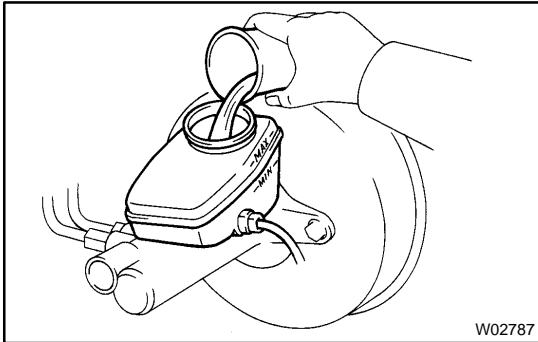

W02787

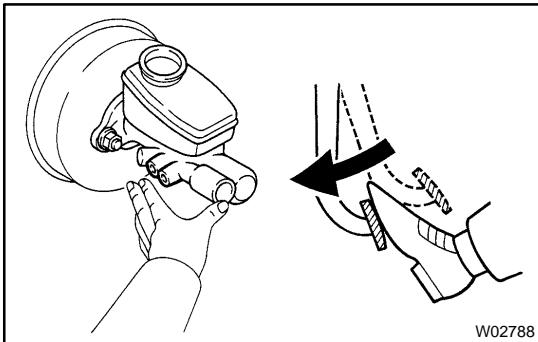

W02788

### 3. BLEED MASTER CYLINDER

#### HINT:

If the master cylinder has been disassembled or if the reservoir becomes empty, bleed the master cylinder.

- (a) Disconnect the brake lines from the master cylinder.
- (b) Slowly depress the brake pedal and hold it.
- (c) Block off the outer holes with your fingers, and release the brake pedal.
- (d) Repeat (b) 3 or 4 times.

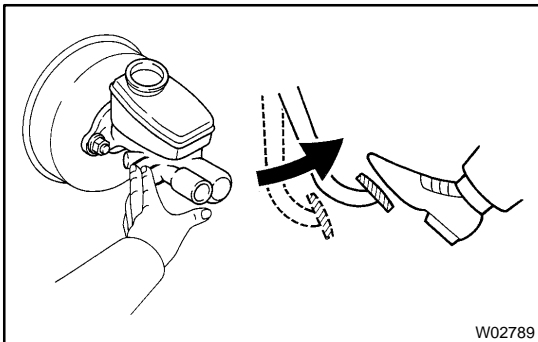

W02789

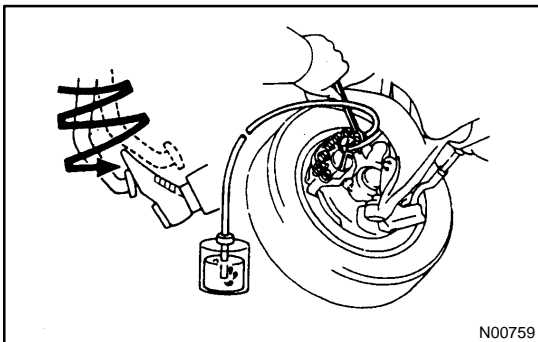

N00759

### 4. BLEED BRAKE LINE

- (a) Connect the vinyl tube to the brake caliper.
- (b) Depress the brake pedal several times, then loosen the bleeder plug with the pedal held down.
- (c) At the point when fluid stops coming out, tighten the bleeder plug, then release the brake pedal.
- (d) Repeat (b) and (c) until all the air in the fluid has been bled out.

**Torque: (Bleeder plug)**  
**11 N·m (110 kgf·cm, 8 ft·lbf)**

(e) Repeat the procedure on the previous page to bleed the brake line for each wheel of air.

**5. CHECK FLUID LEVEL IN RESERVOIR**

Check the fluid level and add fluid if necessary.

**6. INSTALL RESERVOIR CAP**

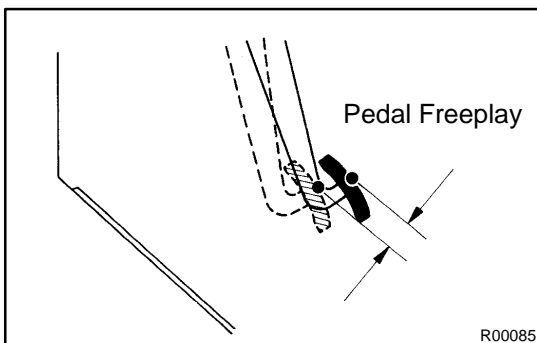
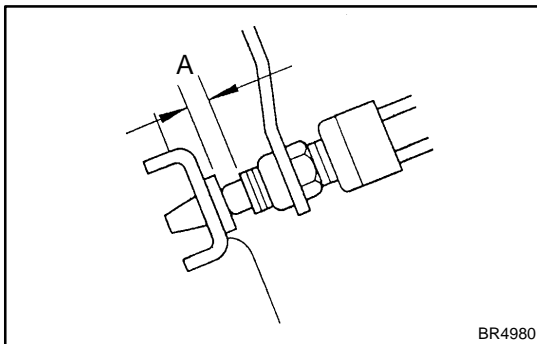
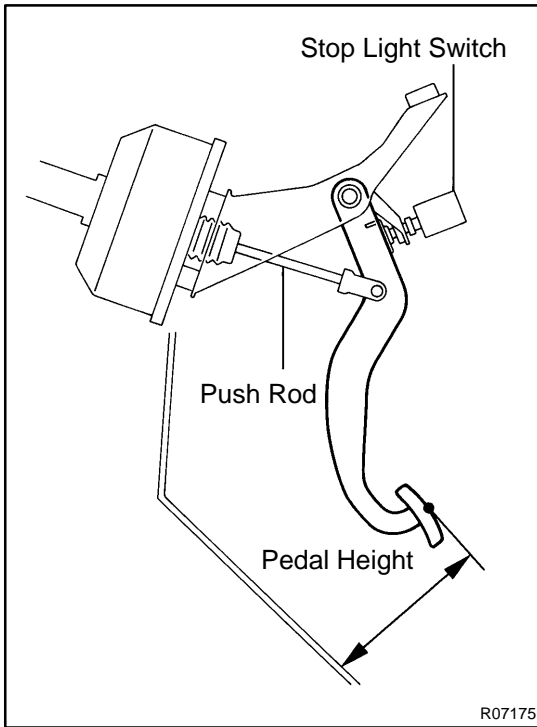

## BRAKE PEDAL ON-VEHICLE INSPECTION

BR1AW-01

### 1. CHECK THAT PEDAL HEIGHT IS CORRECT

**Pedal height from asphalt sheet:  
154.2 - 164.2 mm (6.071 - 6.465 in.)**

If the pedal height is incorrect, adjust it.

### 2. IF NECESSARY, ADJUST PEDAL HEIGHT

- Remove the lower instrument panel and finish panel.
  - Disconnect the connector from the stop light switch.
  - Loosen the stop light switch lock nut and remove the stop light switch.
  - Loosen the push rod lock nut.
  - Adjust the pedal height by turning the pedal push rod.
  - Tighten the push rod lock nut.
- Torque: 25 N·m (260 kgf·cm, 19 ft·lbf)**
- Install the stop light switch and turn it until it lightly contacts the pedal stopper.
  - Turn the stop light switch back one turn.

- Check the clearance (A) between stop lights switch and pedal.

**Clearance: 0.5 - 2.4 mm (0.020 - 0.094 in.)**

- Tighten the stop light switch lock nut.
- Connect the connector to the stop light switch.
- Check that the stop lights come on when the brake pedal is depressed, and go off when the brake pedal is released.
- After adjusting the pedal height, check the pedal freeplay. If clearance (A) between the stop light switch and the brake pedal stopper has been adjusted correctly, the pedal freeplay will meet the specifications.
- Install the lower instrument panel and finish panel.

### 3. CHECK PEDAL FREEPLAY

- Stop the engine and depress the brake pedal several times until there is no more vacuum left in the booster.
- Push in the pedal by hand until the second point of resistance begins to be felt, then measure the distance, as shown.

**Pedal freeplay: 1 - 6 mm (0.04 - 0.24 in.)**

If incorrect, check the stop light switch clearance. If the clearance is OK, then troubleshoot the brake system.

**HINT:**

The freeplay to the 1st point of resistance is due to the play between the clevis and pin. It is 1 - 3 mm (0.04-0.12 in.) on the pedal.

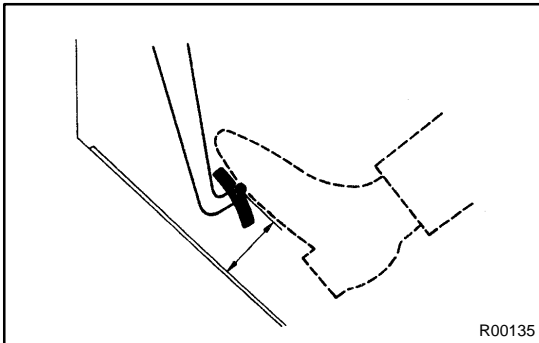
**4. CHECK PEDAL RESERVE DISTANCE**

- (a) Release the parking brake.
- (b) With the engine running, depress the pedal and measure the pedal reserve distance, as shown.

**Pedal reserve distance at 490 N (50 kgf, 110.2 lbf):**

**2JZ-GE Engine: More than 72 mm (2.83 in.)**

**2JZ-GTE Engine: More than 70 mm (2.76 in.)**

If the reserve distance is incorrect, troubleshoot the brake system.

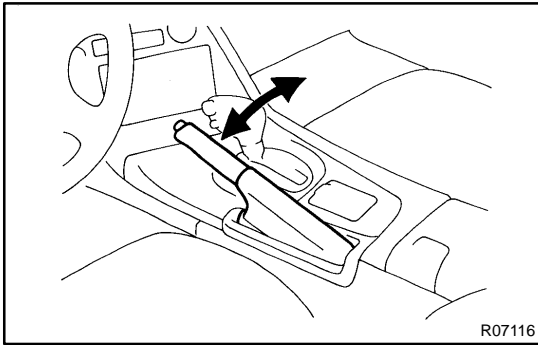

## PARKING BRAKE LEVER ON-VEHICLE INSPECTION

BR0GD-01

### 1. CHECK PARKING BRAKE LEVER TRAVEL

Pull the parking brake lever all the way up, and count the number of clicks.

**Parking brake lever travel at 196 N (20 kgf, 44.1 lbf):  
5 - 8 clicks**

If incorrect, adjust the parking brake.

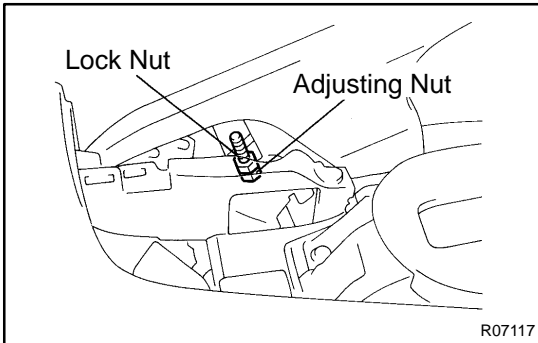

### 2. IF NECESSARY, ADJUST PARKING BRAKE

#### HINT:

Before adjusting the parking brake, make sure that the rear brake shoe clearance has been adjusted. For shoe clearance adjustment, see page [BR-64](#).

- (a) Remove the upper console panel.
- (b) Remove the screw and parking brake hole cover.
- (c) Using a socket driver and spanner wrench, remove the adjusting lock nut.
- (d) Turn the adjusting nut until the lever travel is correct.
- (e) Install the adjusting lock nut.
- (f) Using a socket driver and spanner wrench, tighten the adjusting lock nut.

**Torque: 5.4 N·m (55 kgf·cm, 48 in.-lbf)**

- (g) Install the parking brake hole cover with the screw.
- (h) Install the upper console panel.



# BRAKE MASTER CYLINDER COMPONENTS

BR0GE-02

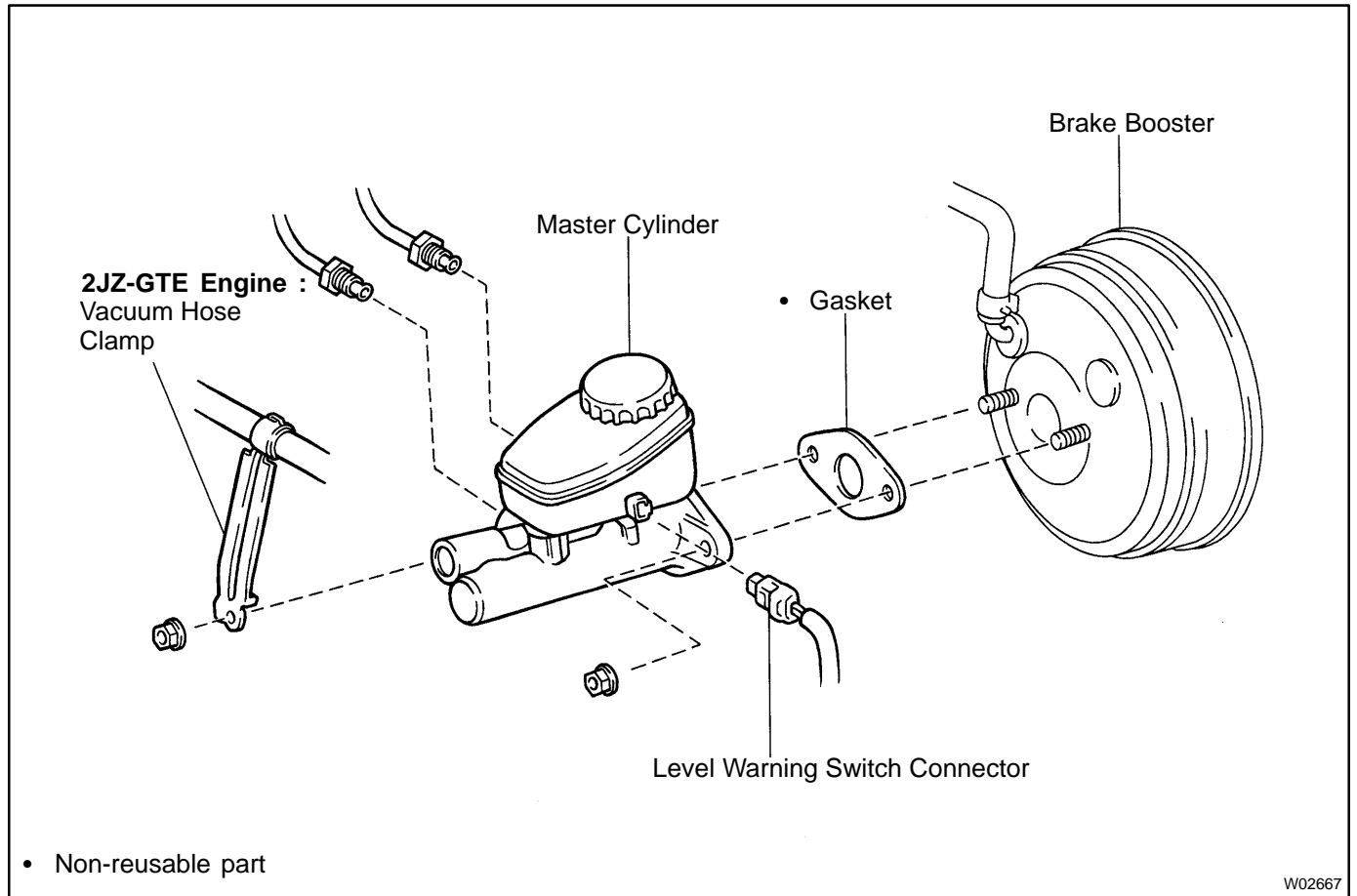

W02667

BRAKE - BRAKE MASTER CYLINDER

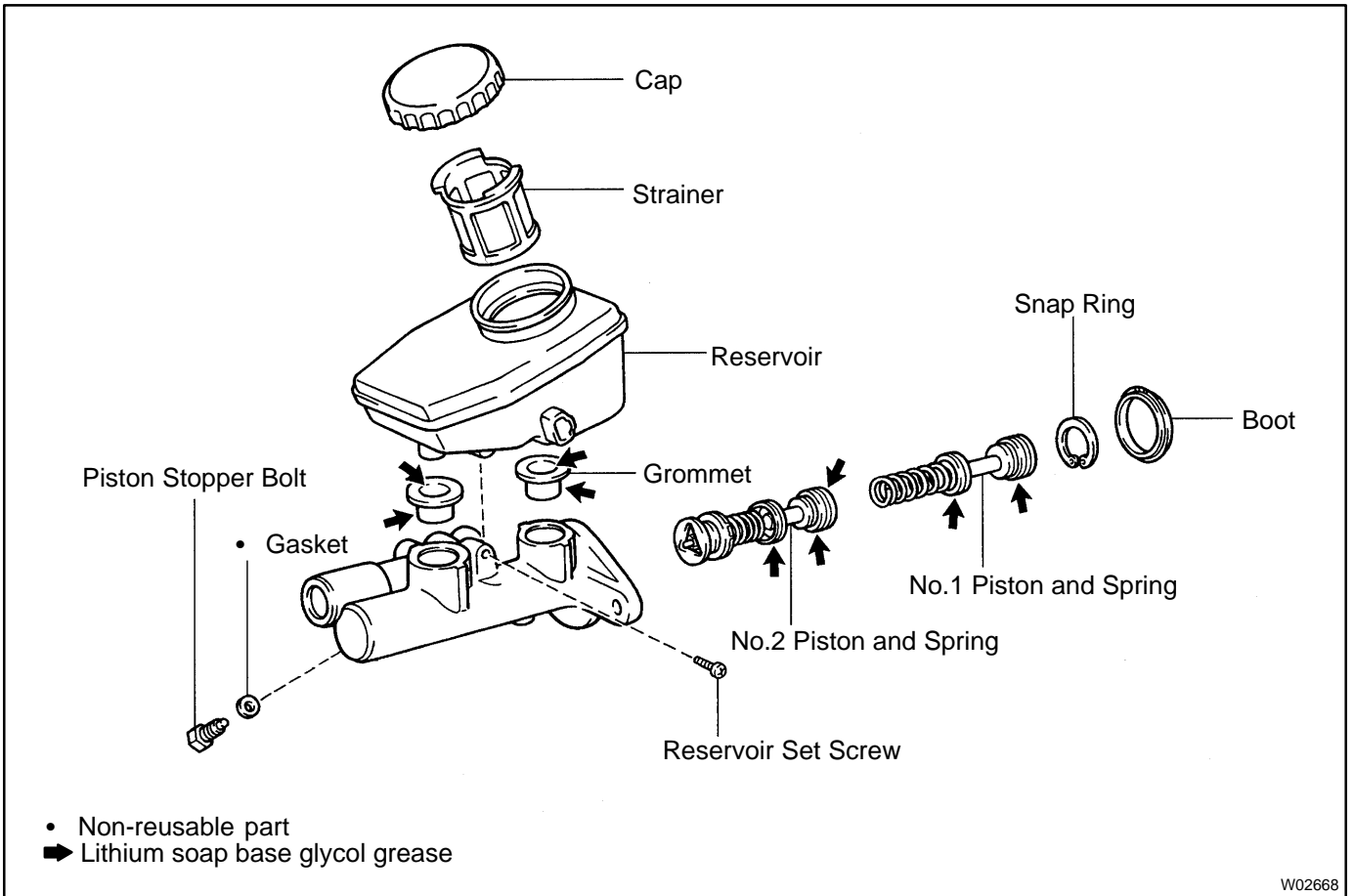

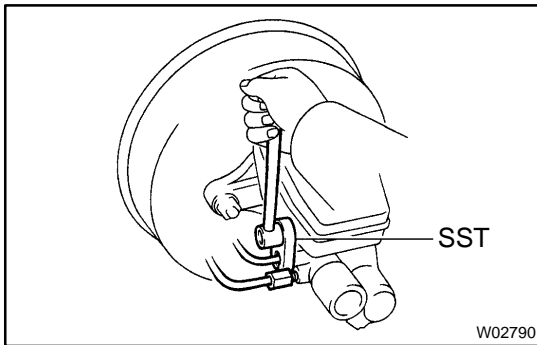

## REMOVAL

1. **DISCONNECT LEVEL WARNING SWITCH CONNECTOR**
2. **DRAW OUT FLUID WITH SYRINGE**

### NOTICE:

**Do not let brake fluid remain on a painted surface. Wash it off immediately.**

3. **DISCONNECT BRAKE LINES**

Using SST, disconnect the brake lines from the master cylinder.

SST 09023-00100

**Torque: 15 N·m (155 kgf·cm, 11 ft·lbf)**

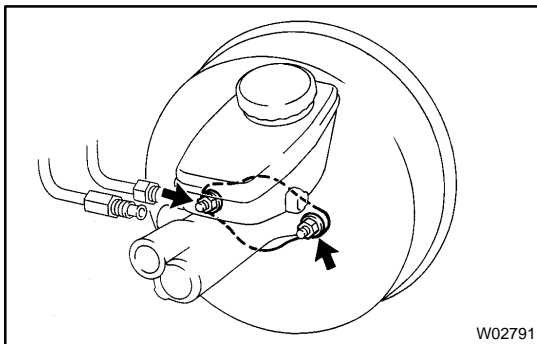

4. **REMOVE MASTER CYLINDER**

- (a) Remove the 2 nuts.

**Torque: 13 N·m (130 kgf·cm, 9 ft·lbf)**

- (b) 2JZ-GE Engine:

Remove the master cylinder and gasket from the brake booster.

- (c) 2JZ-GTE Engine:

Remove the vacuum hose clamp, master cylinder and gasket from the brake booster.

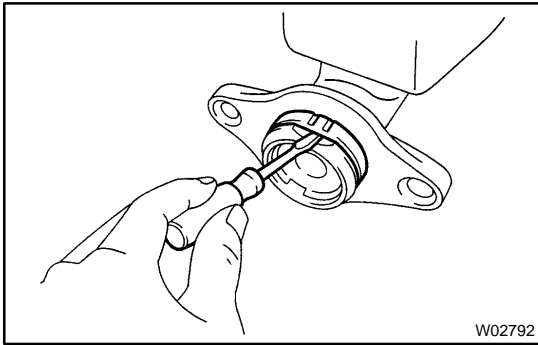

## DISASSEMBLY

### 1. REMOVE MASTER CYLINDER BOOT

Using a screwdriver, remove the master cylinder boot.

#### NOTICE:

At the time of reassembly, please refer to the following item.

Facing the UP mark on the master cylinder boot upwards, install the cylinder boot to the master cylinder.

### 2. REMOVE RESERVOIR CAP AND STRAINER

### 3. REMOVE RESERVOIR

Remove the set screw and pull out the reservoir.

**Torque: 1.8 N·m (18 kgf·cm, 16 in.-lbf)**

### 4. REMOVE 2 GROMMETS

### 5. PLACE CYLINDER IN VISE

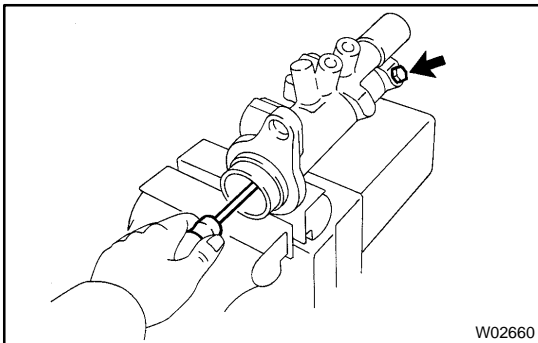

### 6. REMOVE PISTON STOPPER BOLT

Using a screwdriver, push the pistons in all the way and remove the No.2 piston stopper bolt and gasket.

**Torque: 10 N·m (100 kgf·cm, 7 ft-lbf)**

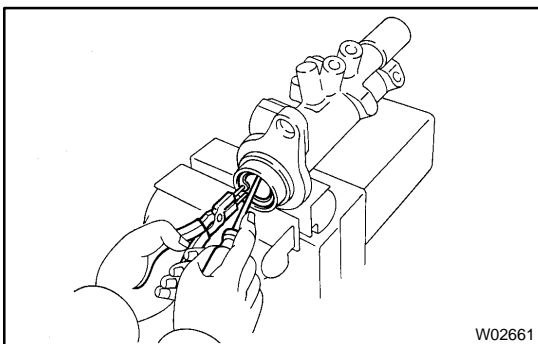

### 7. REMOVE 2 PISTONS

- (a) Push in the piston with a screwdriver and remove the snap ring with snap ring pliers.

#### HINT:

Tape the screwdriver tip before use.

- (b) Remove the No. 1 piston and spring by hand, pulling straight out, not at an angle.

#### NOTICE:

- If pulled out and install at an angle, there is a possibility that the cylinder bore could be damaged.
- At the time of reassembly, be careful not to damage the rubber lips on the pistons.

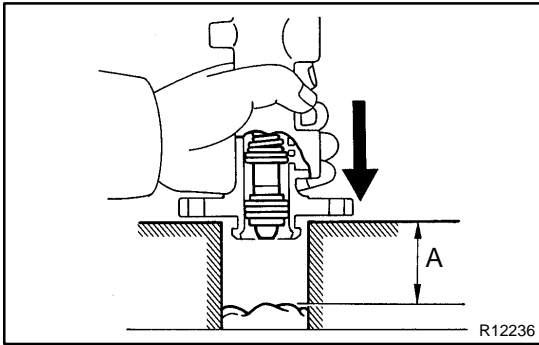

- (c) Place a rag and 2 wooden blocks on the work table and lightly tap the cylinder flange against the block edges until the piston drops out of the cylinder.

HINT:

Make sure the distance (A) from the rag to the top of the blocks is at least 100 mm (3.94 in.).

## INSTALLATION

Installation is in the reverse order of removal (See page [BR-12](#) ).

1. BEFORE INSTALLATION, ADJUST LENGTH OF BRAKE BOOSTER PUSH ROD  
(See page [BR-21](#) )
2. AFTER INSTALLATION, FILL BRAKE FLUID AND BLEED BRAKE SYSTEM (See page [BR-5](#) )
3. CHECK FOR LEAKS, CHECK AND ADJUST BRAKE PEDAL (See page [BR-7](#) )

# COMPONENTS

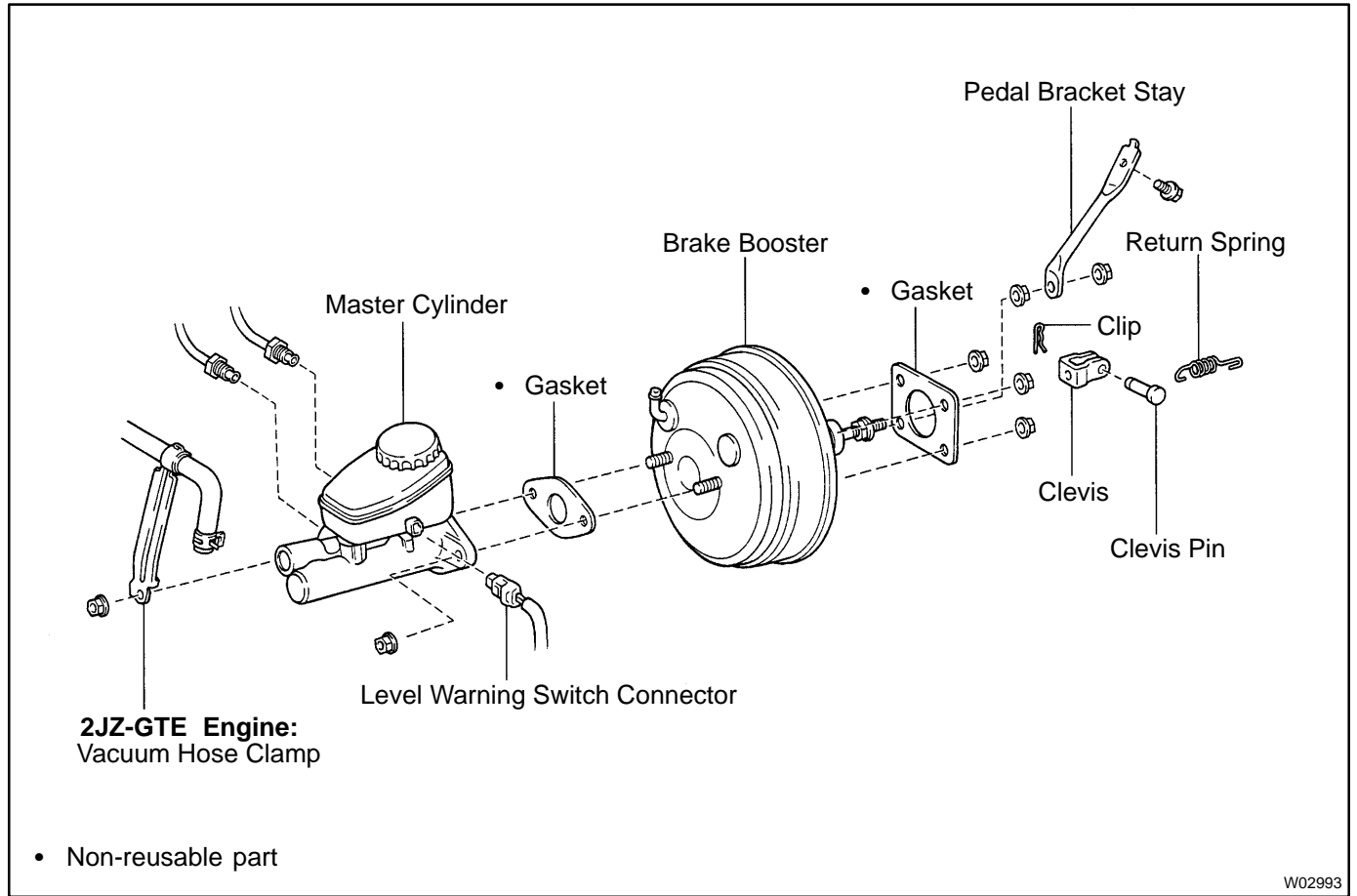

W02993

## REMOVAL

### 1. REMOVE THESE PARTS

- Master cylinder (See page [BR-12](#) )
- Vacuum hose
- Clip, clevis pin and return spring

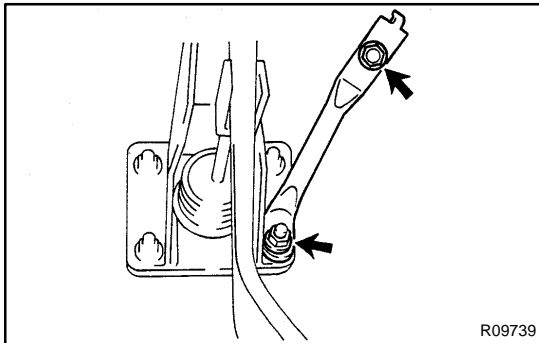

### 2. REMOVE PEDAL BRACKET STAY

- (a) Remove the steering column assembly (See page [SR-11](#)).
- (b) Remove the bolt and nut.
- (c) Remove the pedal bracket stay.

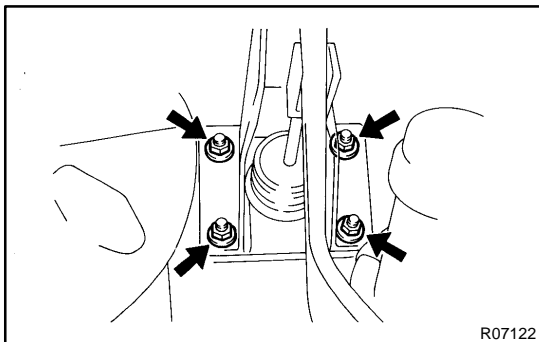

### 3. REMOVE BRAKE BOOSTER

- (a) Remove the 4 booster installation nuts and clevis.
- (b) Remove the booster and gasket.



## INSTALLATION

### 1. INSTALL BRAKE BOOSTER

- Install the booster and a new gasket.
- Install the clevis to the operating rod.
- Install and torque the booster installation nuts.  
**Torque: 13 N·m (130 kgf·cm, 9 ft·lbf)**
- Insert the clevis pin into the clevis and brake pedal, and install the clip to the clevis pin.
- Install the pedal return spring.

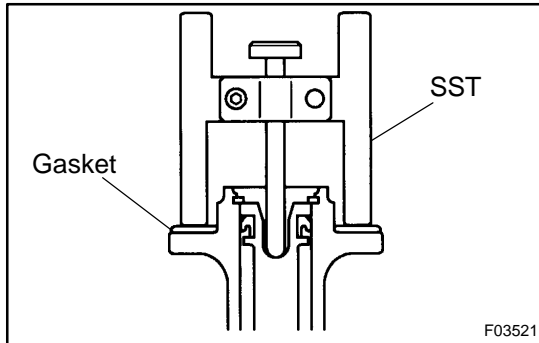

### 2. ADJUST LENGTH OF BOOSTER PUSH ROD

- Install the gasket on the master cylinder.
- Set the SST on the gasket, and lower the pin until its tip slightly touches the piston.  
SST 09737-00010
- Turn the SST upside down, and set it on the booster.  
SST 09737-00010
- Measure the clearance between the booster push rod and pin head (SST).  
**Clearance: 0 mm (0 in.)**
- Adjust the booster push rod length until the push rod lightly touches the pin head.

#### HINT:

When adjusting the push rod, depress the brake pedal enough so that the push rod sticks out.

### 3. INSTALL PEDAL BRACKET STAY

- Install the pedal bracket stay.
- Install the bolt and nut.
- Install the steering column assembly (See page [SR-21](#)).

### 4. INSTALL THESE PARTS

- Vacuum hose
- Master cylinder (See page [BR-17](#))

### 5. FILL BRAKE RESERVOIR WITH BRAKE FLUID AND BLEED BRAKE SYSTEM (See page [BR-5](#))

### 6. CHECK FOR FLUID LEAKAGE

### 7. CHECK AND ADJUST BRAKE PEDAL

(See page [BR-7](#))

### 8. DO OPERATIONAL CHECK (See page [BR-18](#))

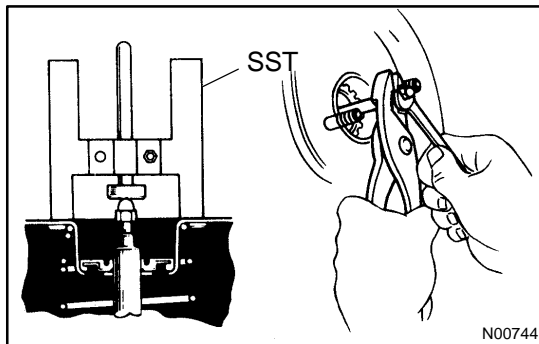

# FRONT BRAKE PAD (2JZ-GTE) COMPONENTS

BR09Q-01

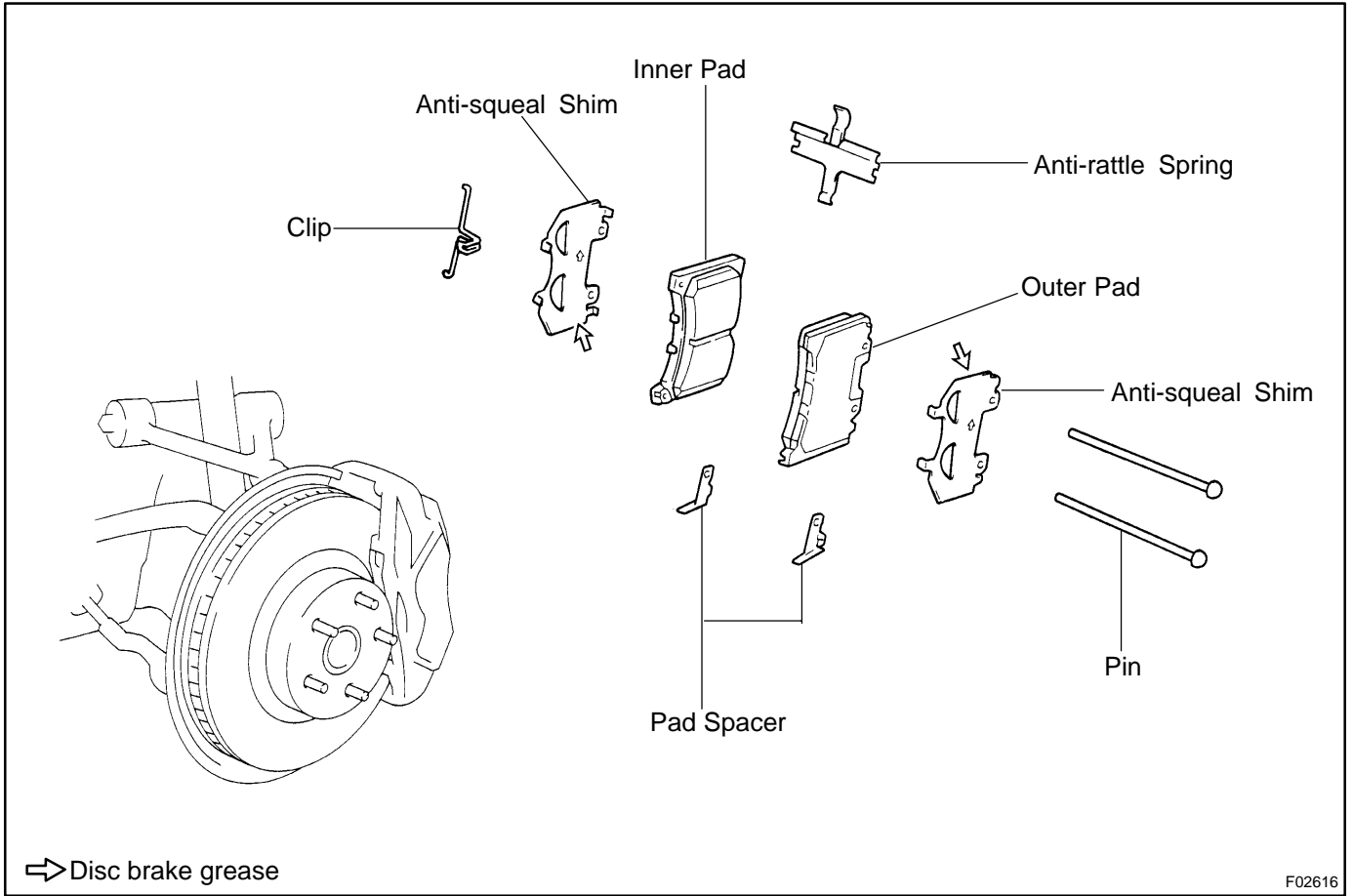

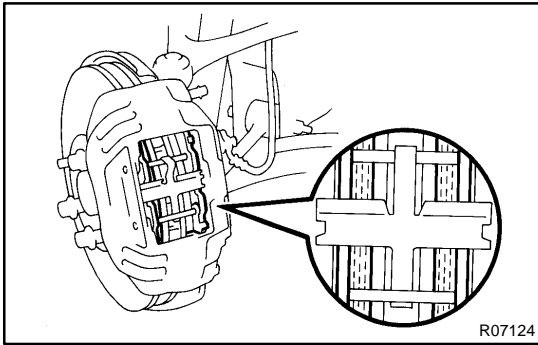

## REPLACEMENT

### 1. REMOVE FRONT WHEEL

Remove the wheel and temporarily fasten the disc with the hub nuts.

### 2. INSPECT PAD LINING THICKNESS

Check the pad thickness and replace pads if they are not within specification.

**Minimum thickness: 1.0 mm (0.039 in.)**

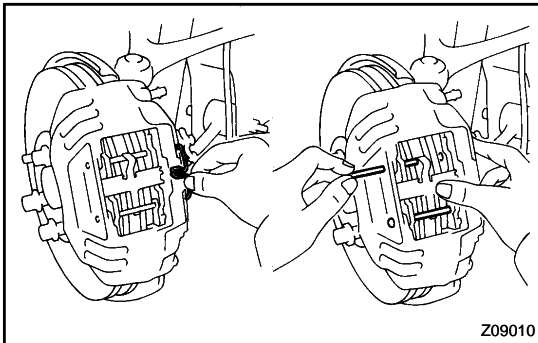

### 3. REMOVE THESE PARTS

- (a) Clip and 2 pins
- (b) Anti-rattle spring
- (c) 2 pads
- (d) 2 pad spacers
- (e) 2 anti-squeal shims

#### NOTICE:

The anti-rattle spring, clip and pad spacers can be used again provided that they have sufficient rebound, no deformation, cracks or wear, and have had all rust, dirt and foreign particles cleaned off.

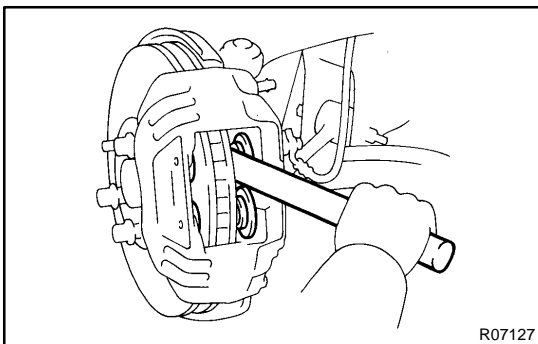

### 4. CHECK DISC THICKNESS AND RUNOUT

(See page [BR-39](#))

### 5. INSTALL NEW PADS

#### NOTICE:

When replacing worn pads, the anti-squeal shims must be replaced together with the pads.

- (a) Draw out a small amount of brake fluid from the reservoir.
- (b) Press in the pistons with a hammer handle or equivalent.

#### HINT:

- Always change the pads on one wheel at a time as there is a possibility of the opposite piston flying out.
- If the piston is difficult to push in, loosen the bleeder plug and push in the piston while letting some brake fluid escape.

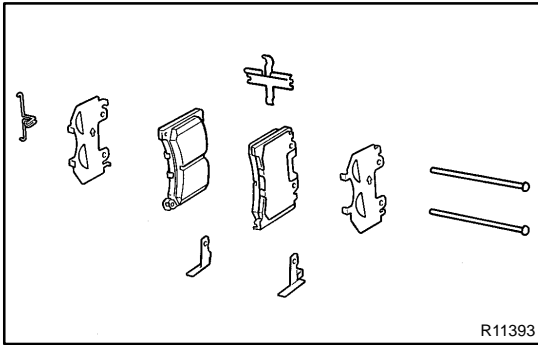

(c) Install the anti-squeal shim on each pad.

HINT:

- Place the pad wear indicator facing downward.
  - Apply disc brake grease to inner side of the anti-squeal shims (See page [BR-25](#) ).
  - Make sure that the arrow on the shims points upward.
- (d) Install a pad spacer on the lower side of the each pad.  
 (e) Install the 2 pads.

**NOTICE:**

**Do not allow oil or grease to get on the rubbing face.**

**6. INSTALL ANTI-RATTLE SPRING AND 2 PINS**

**7. INSTALL CLIP**

# FRONT BRAKE CALIPER (2JZ-GTE) COMPONENTS

BR0GY-02

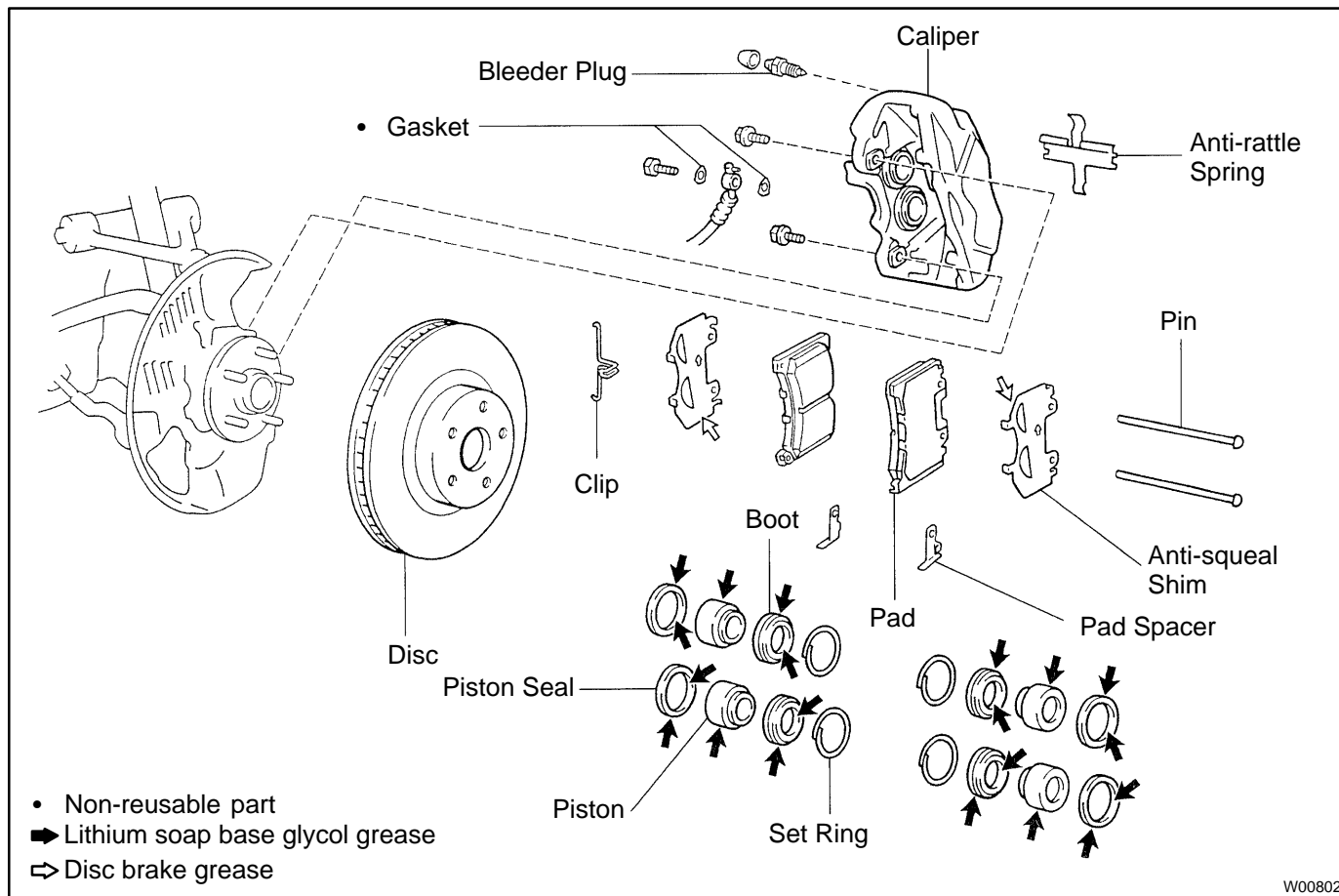

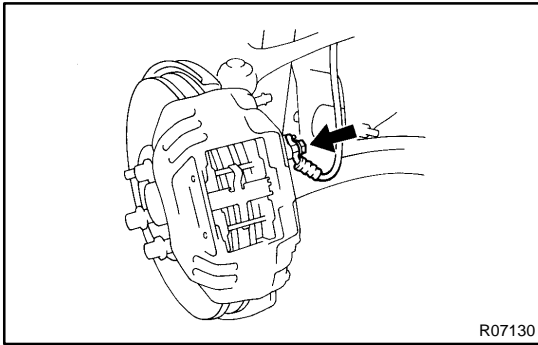

R07130

## REMOVAL

### 1. REMOVE FRONT WHEEL

### 2. DISCONNECT FLEXIBLE HOSE

- (a) Remove the union bolt and 2 gaskets from the caliper, then disconnect the flexible hose from the caliper.

**Torque: 30 N·m (310 kgf·cm, 22 ft·lbf)**

#### HINT:

At the time of installation, please refer to the following item.

Install the flexible hose lock securely in the lock hole in the caliper.

- (b) Use a container to catch the brake fluid as it drains out.

### 3. REMOVE CALIPER

Remove the 2 mounting bolts and caliper.

**Torque: 118 N·m (1,200 kgf·cm, 87 ft·lbf)**

### 4. REMOVE THESE PARTS

- (a) Clip and 2 pins  
 (b) Anti-rattle spring  
 (c) 2 pads  
 (d) 2 pad spacers and anti-squeal shims



R07131

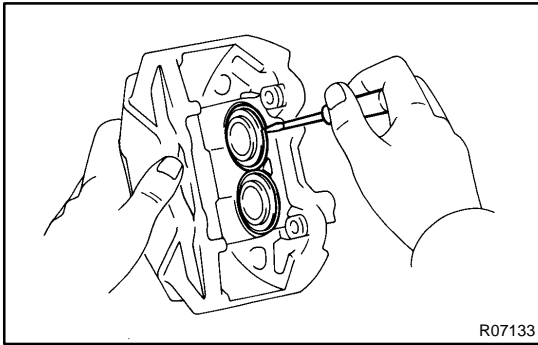

R07133

## DISASSEMBLY

### 1. REMOVE CYLINDER BOOT SET RINGS AND BOOTS

Using a screwdriver, remove the 4 cylinder boot set rings and 4 boots.

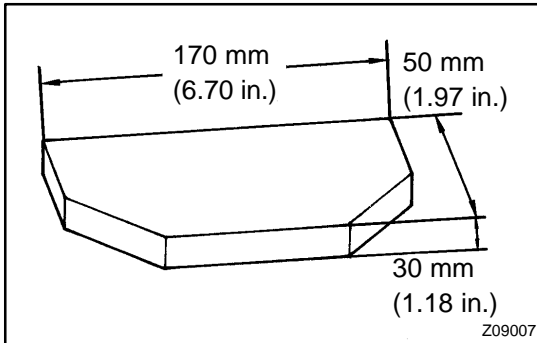

Z09007

### 2. REMOVE PISTONS FROM CYLINDER

(a) Prepare a wooden plate to hold the pistons.

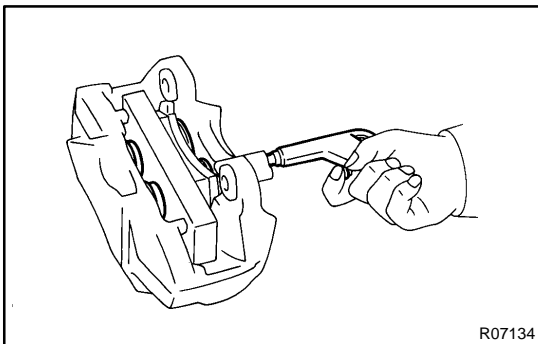

R07134

(b) Place the plate between the pistons and insert a pad on one side.

(c) Use compressed air to remove the pistons alternately from the cylinder.

#### CAUTION:

**Do not place your fingers in front of the pistons when using compressed air.**

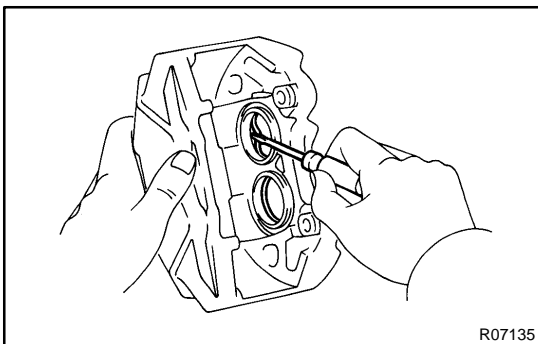

R07135

### 3. REMOVE PISTON SEALS

Using a screwdriver, remove the 4 piston seals from the cylinder.

## INSPECTION

1. **MEASURE PAD LINING THICKNESS**  
(See page [BR-32](#))  
Standard thickness: 12.0 mm (0.472 in.)  
Minimum thickness: 1.0 mm (0.039 in.)
2. **MEASURE DISC THICKNESS**  
(See page [BR-32](#))  
Standard thickness: 30.0 mm (1.181 in.)  
Minimum thickness: 28.0 mm (1.102 in.)
3. **MEASURE DISC RUNOUT**  
(See page [BR-32](#))  
Maximum disc runout: 0.05 mm (0.0020 in.)

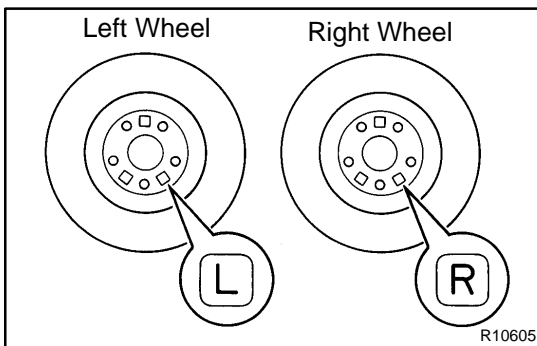

4. **IF NECESSARY, ADJUST DISC RUNOUT**  
(See page [BR-32](#))

**HINT:**

Install a disc marked with "R" on the right wheel, and a disc marked with "L" on the left wheel.



# REAR BRAKE PAD (2JZ-GTE) COMPONENTS

BR0H6-01

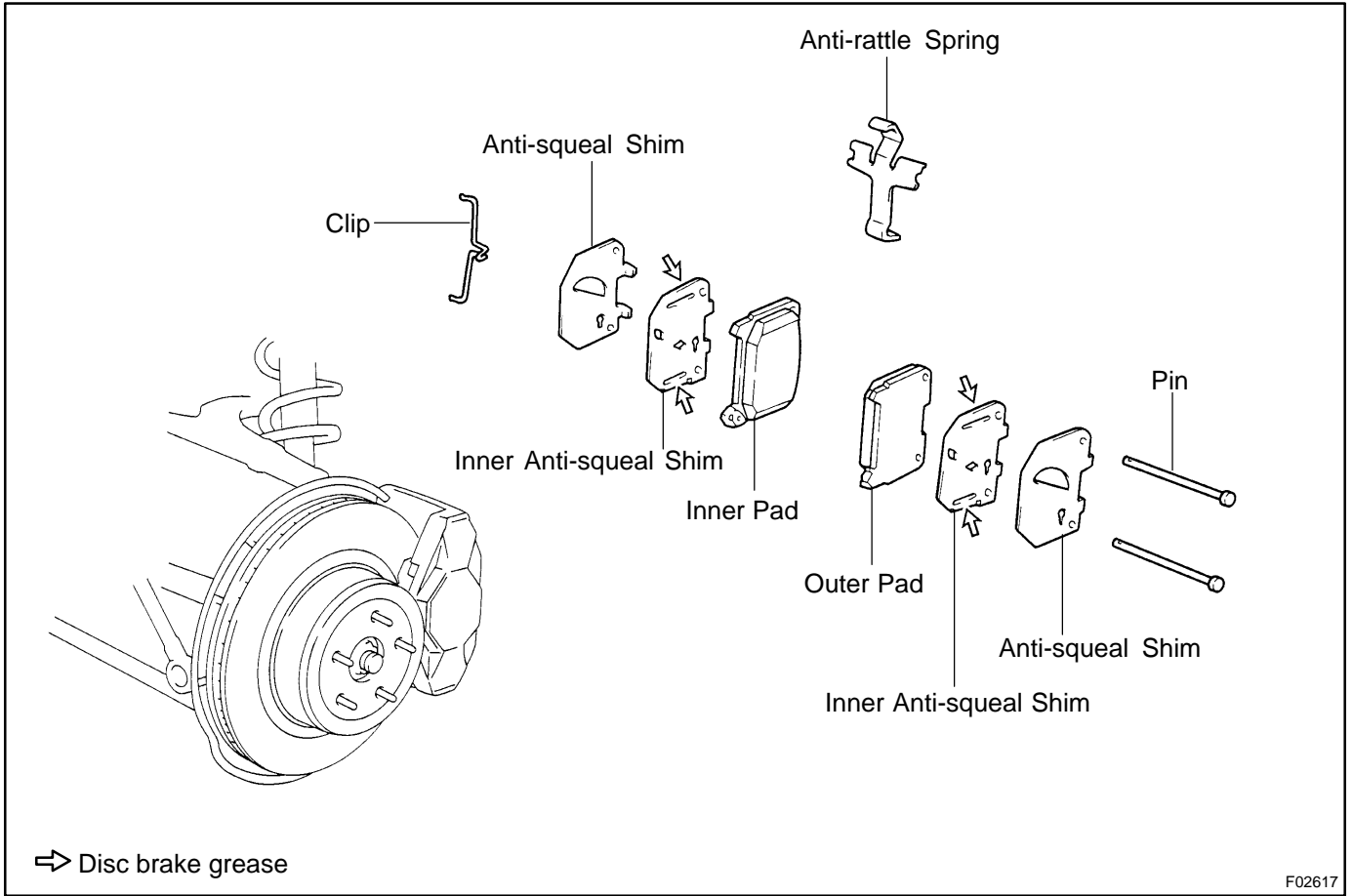

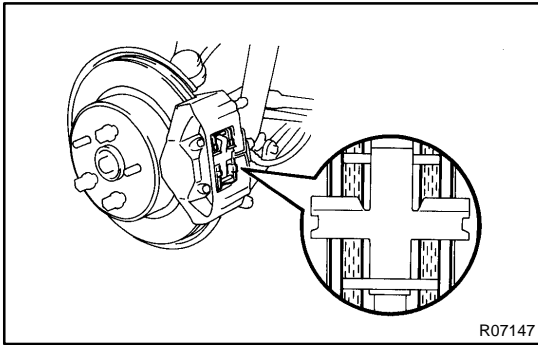

## REPLACEMENT

### 1. REMOVE REAR WHEEL

Remove the wheel and temporarily fasten the disc with the hub nuts.

### 2. INSPECT PAD LINING THICKNESS

Check the pad thickness and replace pads if they are not within specification.

**Minimum thickness: 1.0 mm (0.039 in.)**

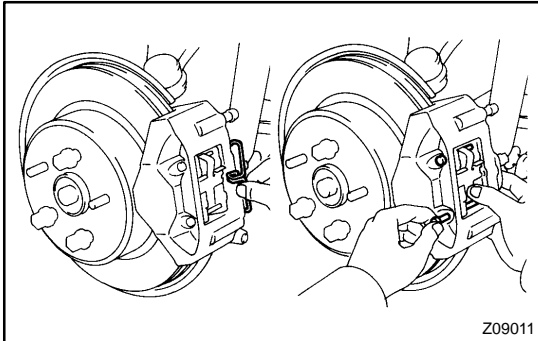

### 3. REMOVE THESE PARTS

- (a) Clip and 2 pins
- (b) Anti-rattle spring
- (c) 2 pads
- (d) 4 anti-squeal shims

#### NOTICE:

The anti-rattle springs and clip can be used again provided that they have sufficient rebound, no deformation, cracks or wear, and have had all rust, dirt and foreign particles cleaned off.

### 4. CHECK DISC THICKNESS AND RUNOUT

(See page [BR-57](#))

### 5. INSTALL NEW PADS

#### NOTICE:

When replacing worn pads, the anti-squeal shims must be replaced together with the pads.

- (a) Draw out a small amount of brake fluid from the reservoir.
- (b) Press in the pistons with a hammer handle or equivalent.

#### HINT:

- Always change the pads on one wheel at a time as there is a possibility of the opposite piston flying out.
- If the piston is difficult to push in, loosen the bleeder plug and push in the piston while letting some brake fluid escape.

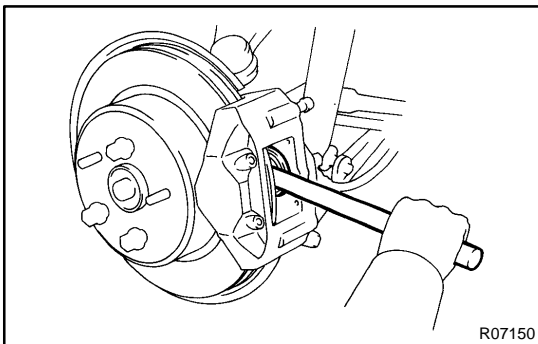

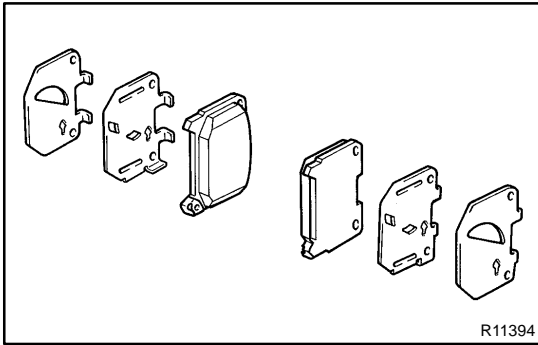

(c) Install the 2 anti-squeal shims on each pad.

HINT:

- Apply disc brake grease to both sides of the inner anti-squeal shim (See page [BR-45](#) ).
- Make sure that the arrow on the shims points upward.

(d) Install the 2 pads with pad wear indicator plates facing downward.

**NOTICE:**

**Do not allow oil or grease to get on the rubbing face.**

**6. INSTALL ANTI-RATTLE SPRING AND 2 PINS**

**7. INSTALL CLIP**

# REAR BRAKE CALIPER (2JZ-GTE) COMPONENTS

BR0HE-02

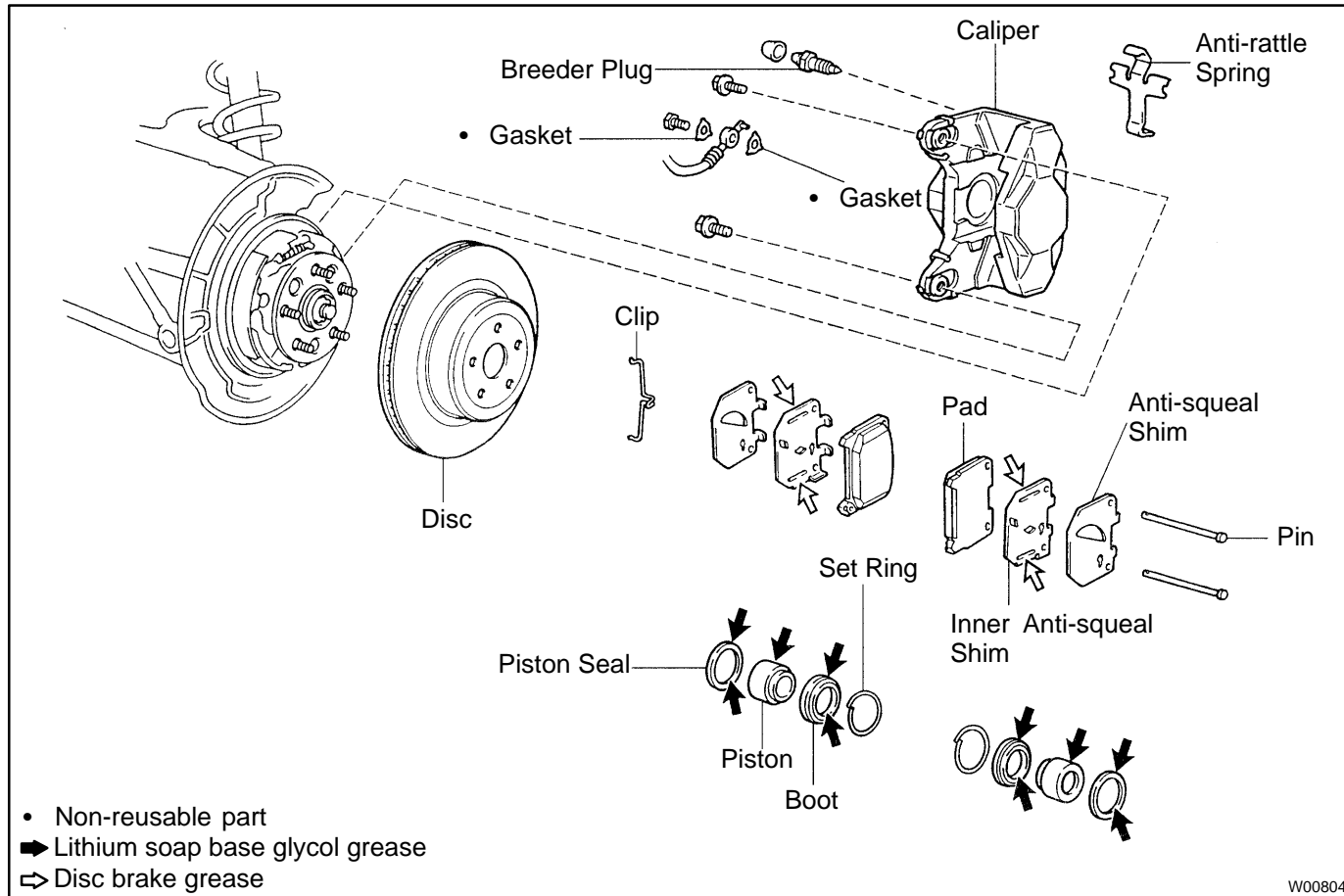

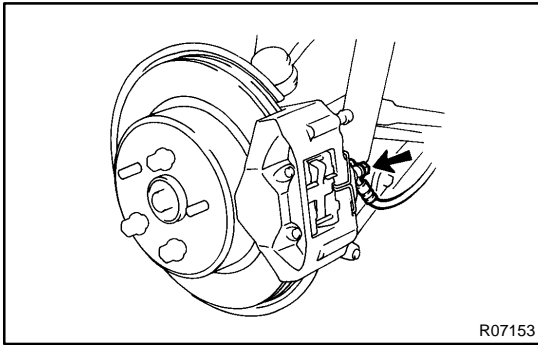

## REMOVAL

1. **REMOVE REAR WHEEL**
2. **DISCONNECT FLEXIBLE HOSE**
  - (a) Remove the union bolt and 2 gaskets from the caliper, then disconnect the flexible hose from the caliper.  
**Torque: 30 N·m (310 kgf·cm, 22 ft·lbf)**

### HINT:

- At the time of installation, please refer to the following item.  
Install the flexible hose lock securely in the lock hole in the caliper.
- (b) Use a container to catch the brake fluid.

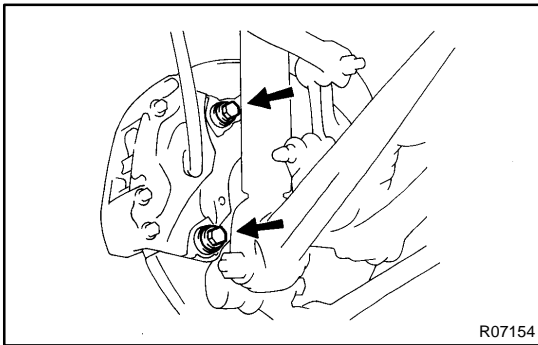

3. **REMOVE CALIPER**  
Remove the 2 mounting bolts and caliper.  
**Torque: 104 N·m (1,065 kgf·cm, 77 ft·lbf)**
4. **REMOVE THESE PARTS**
  - (a) Clip
  - (b) 2 pins
  - (c) Anti-rattle spring
  - (d) 2 pads
  - (e) 4 anti-squeal shims

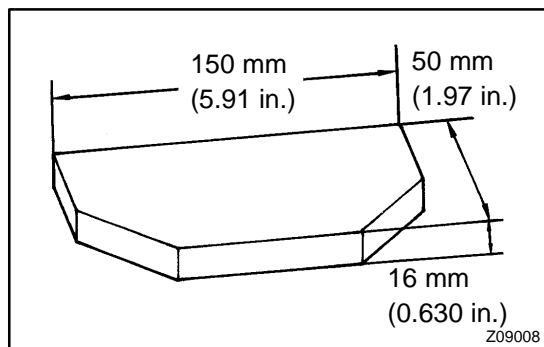

## DISASSEMBLY

1. REMOVE CYLINDER BOOT SET RINGS AND BOOTS  
(See step 1 on page [BR-38](#))
2. REMOVE PISTONS FROM CYLINDER  
(See step 2 on page [BR-38](#))
3. REMOVE PISTON SEALS  
(See step 3 on page [BR-38](#))

## INSPECTION

1. **MEASURE PAD LINING THICKNESS (See page [BR-32](#) )**  
Standard thickness: 11.0 mm (0.433 in.)  
Minimum thickness: 1.0 mm (0.039 in.)
2. **MEASURE DISC THICKNESS (See page [BR-32](#) )**  
Standard thickness: 16.0 mm (0.630 in.)  
Minimum thickness: 15.0 mm (0.591 in.)
3. **MEASURE DISC RUNOUT (See page [BR-32](#) )**  
Maximum disc runout: 0.05 mm (0.0020 in.)
4. **IF NECESSARY, ADJUST DISC RUNOUT (See page [BR-32](#) )**

# PARKING BRAKE COMPONENTS

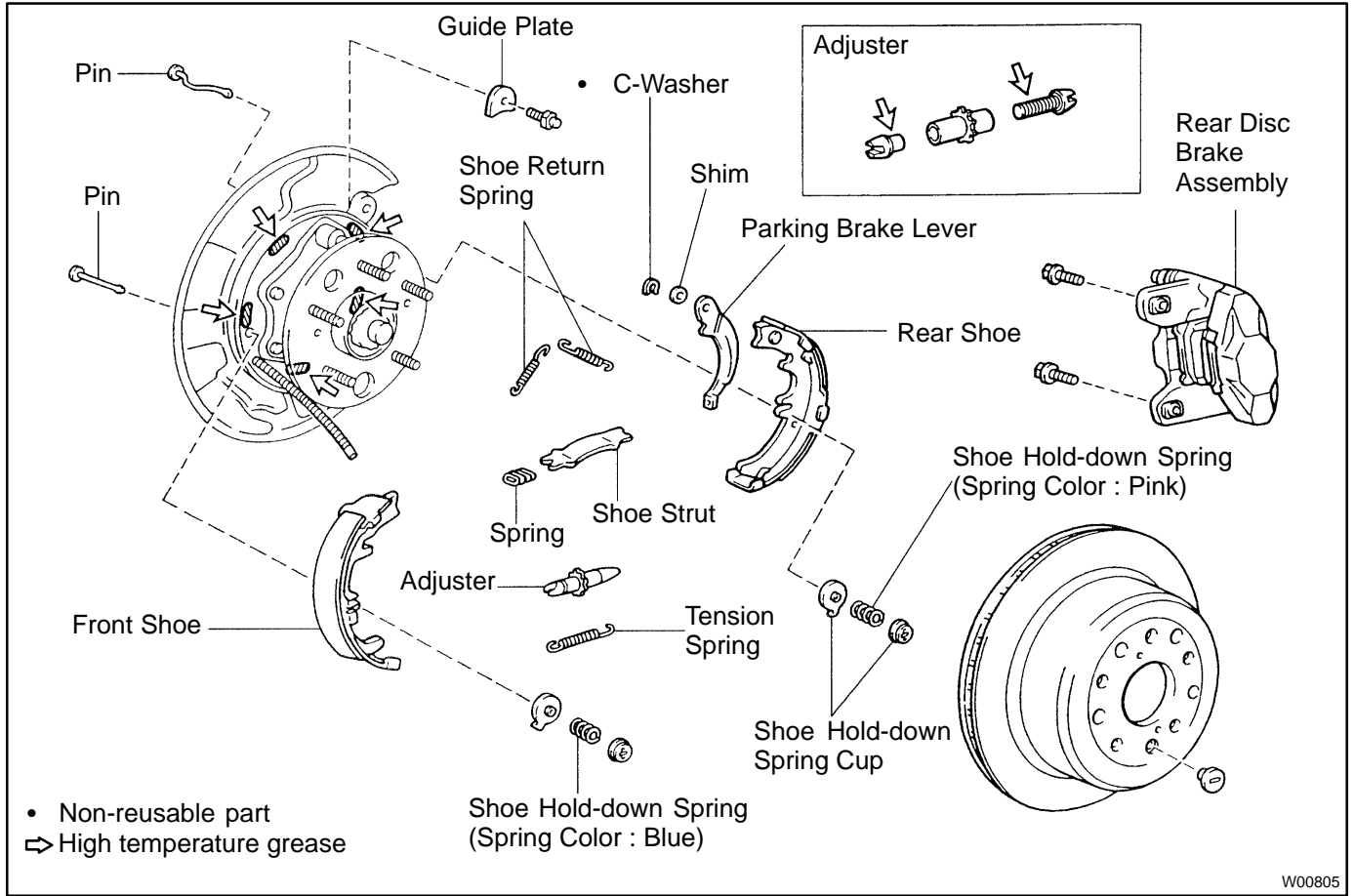



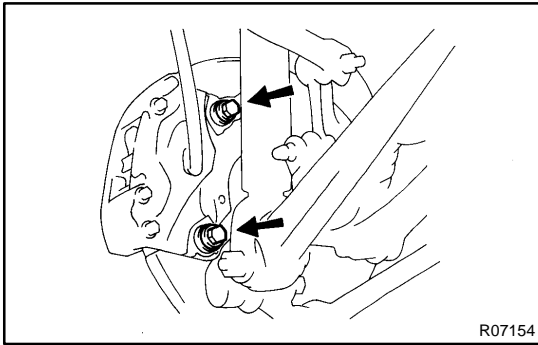

R07154

## DISASSEMBLY

### 1. REMOVE REAR WHEEL

### 2. REMOVE REAR DISC BRAKE ASSEMBLY

- (a) Remove the 2 mounting bolts and remove the disc brake assembly.

**Torque: 104 N·m (1,065 kgf·cm, 77 ft·lbf)**

- (b) Suspend the disc brake securely and so the hose is not stretched.

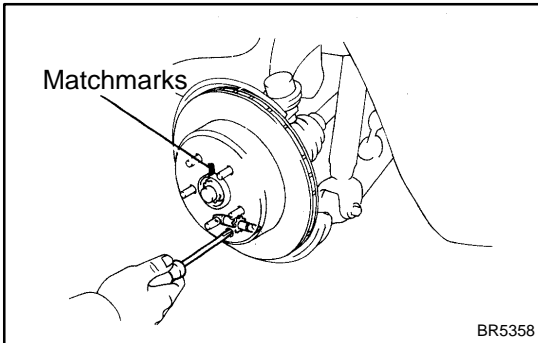

BR5358

### 3. REMOVE DISC

- (a) Place matchmarks on the disc and rear axle hub.

- (b) Remove the disc.

#### HINT:

- If the disc cannot be removed easily, return the shoe adjuster until the disc turns freely.
- If there are no matchmarks, temporarily install the disc, then measure the disc runout and install the disc in the position (See step 4 on page BR-51 ).

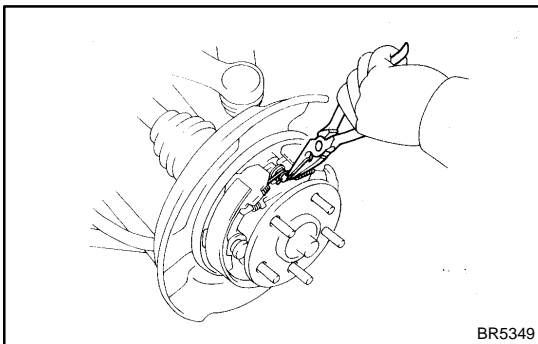

BR5349

### 4. REMOVE SHOE RETURN SPRINGS

Using needle-nose pliers, remove the 2 shoe return springs.

### 5. REMOVE SHOE STRUT WITH SPRING

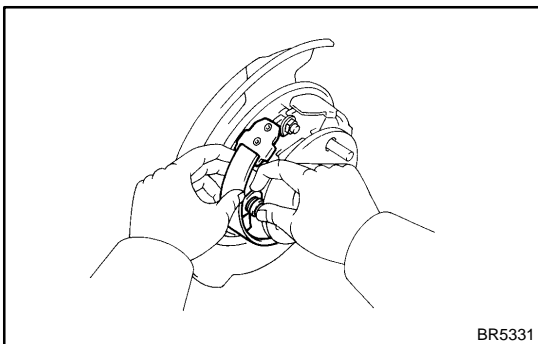

BR5331

### 6. REMOVE FRONT SHOE, ADJUSTER AND TENSION SPRING

- (a) Slide out the front shoe and remove the shoe adjuster.
- (b) Disconnect the tension spring and remove the front shoe.

### 7. REMOVE REAR SHOE

- (a) Slide out the rear shoe.
- (b) Remove the tension spring from the rear shoe.

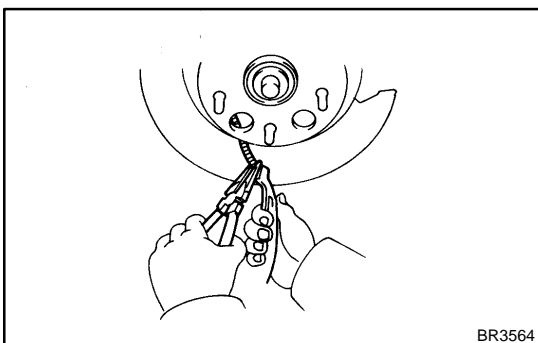

BR3564

- (c) Disconnect the parking brake cable from the parking brake shoe lever.
- (d) Remove the shoe hold-down spring cups, springs and pins.

## INSPECTION

### 1. INSPECT DISASSEMBLED PARTS

Inspect the disassembled parts for wear, rust or damage.

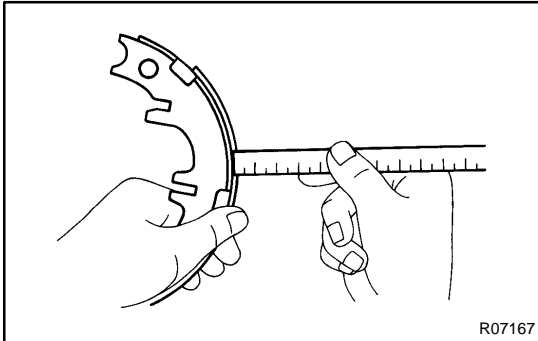

R07167

### 2. MEASURE BRAKE SHOE LINING THICKNESS

Using a ruler, measure the thickness of the shoe lining.

**Standard thickness: 2.5 mm (0.098 in.)**

**Minimum thickness: 1.0 mm (0.039 in.)**

If the lining thickness is at the minimum thickness or less, or if there is severe and uneven wear, replace the brake shoe.

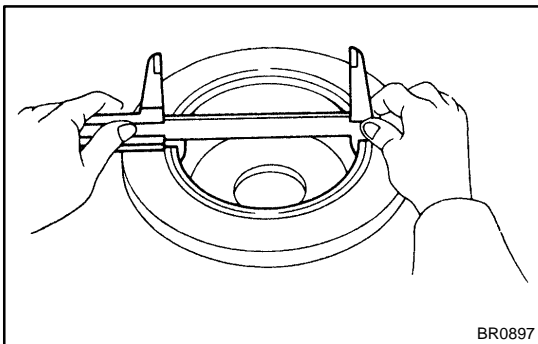

BR0897

### 3. MEASURE BRAKE DISC INSIDE DIAMETER

Using a vernier calipers, measure the inside diameter of the disc.

**Standard inside diameter: 190 mm (7.48 in.)**

**Maximum inside diameter: 191 mm (7.52 in.)**

Replace the disc if the inside diameter is at the maximum value or more. Replace the disc or grind it on a lathe if the disc is badly scored or worn unevenly.

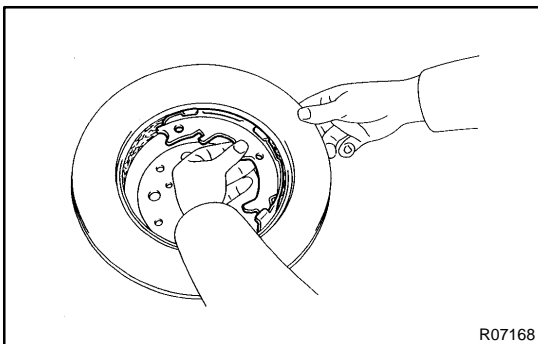

R07168

### 4. INSPECT PARKING BRAKE LINING AND DISC FOR PROPER CONTACT

Apply chalk to the inside surface of the disc, then grind down the brake shoe lining to fit. If the contact between the disc and the brake shoe lining is improper, repair it using a brake shoe grinder or replace the brake shoe assembly.

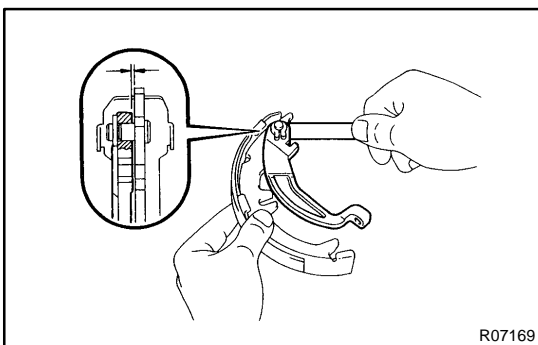

R07169

### 5. MEASURE CLEARANCE BETWEEN PARKING BRAKE SHOE AND LEVER

Using a feeler gauge, measure the clearance.

**Standard clearance: Less than 0.35 mm (0.0138 in.)**

If the clearance is not within the specification, replace the shim with one of the correct size.

Thickness	mm(in.)	Thickness	mm(in.)
0.3	(0.012)	0.9	(0.035)
0.6	(0.024)		

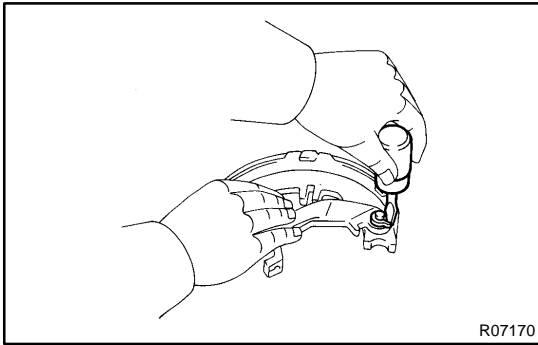
**6. IF NECESSARY, REPLACE SHIM**

- (a) Using a screwdriver, remove the C-washer.
- (b) Remove the shim and parking brake shoe lever, and install the correct sized shim.

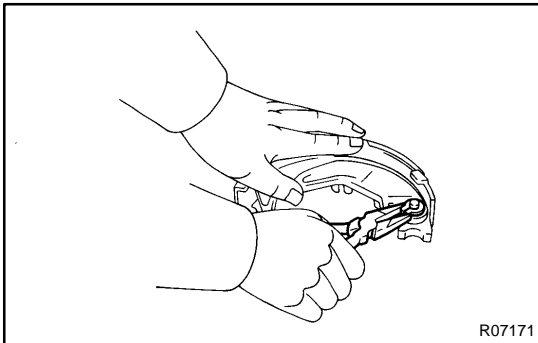

- (c) Install the parking brake shoe lever with a new C-washer.
- (d) Remeasure the clearance.

## REASSEMBLY

Reassembly is in the reverse order of disassembly (See page [BR-61](#) ).

HINT:

Apply high temperature grease to the parts indicated by the arrows (See page [BR-60](#) ).

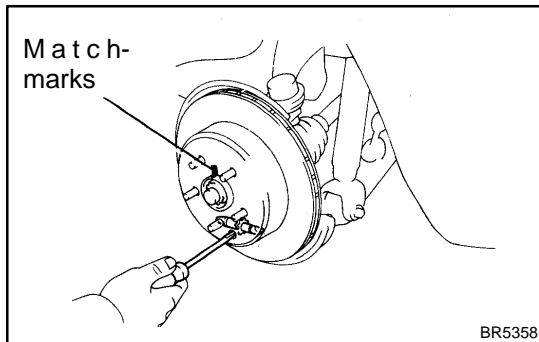

### 1. ADJUST PARKING BRAKE SHOE CLEARANCE

- (a) Temporarily install the hub nuts.
- (b) Remove the hole plug.
- (c) Turn the adjuster and expand the shoes until the disc locks.
- (d) Return the adjuster 8 notches.
- (e) Install the hole plug.

### 2. SETTLING PARKING BRAKE SHOES AND DISC

- (a) Drive the vehicle at about 50 km/h (31 mph) on a safe, level and dry road.
- (b) With the parking brake release button pushed in, pull on the lever with 88 N (9 kgf, 19.8 lbf) of force.
- (c) Drive the vehicle for about 400 meters (0.25 mile) in this condition.
- (d) Repeat this procedure 2 or 3 times.

### 3. CHECK AND ADJUST PARKING BRAKE LEVER TRAVEL (See page [BR-9](#) )

# PROPORTIONING AND BY-PASS VALVE (P & B VALVE)

## ON-VEHICLE INSPECTION

BR0HO-02

### 1. INSTALL LSPV GAUGE (SST) AND BLEED AIR

SST 09709-29017

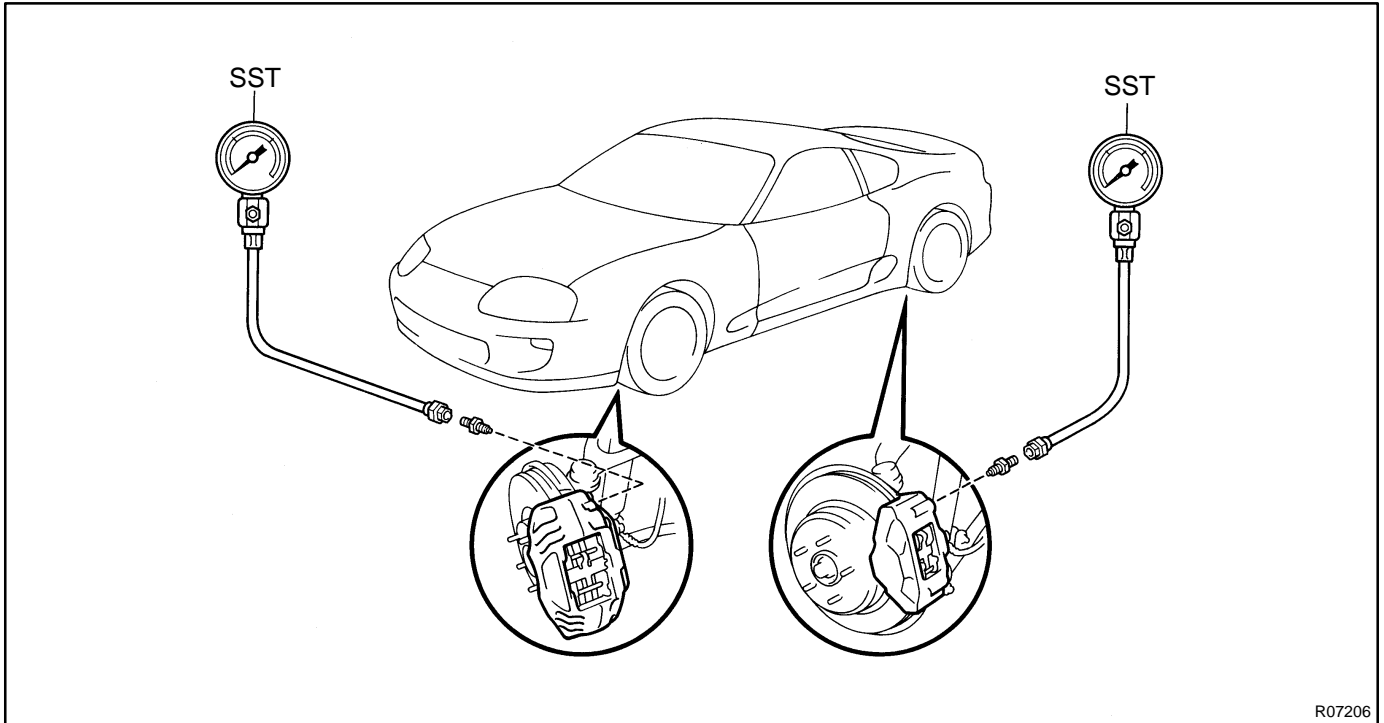

R07206

### 2. RAISE MASTER CYLINDER PRESSURE AND CHECK REAR BRAKE CALIPER PRESSURE

### 3. INSTALL LSPV GAUGE (SST) AND BLEED AIR

SST 09709-29017

### 4. RAISE MASTER CYLINDER PRESSURE AND CHECK REAR BRAKE CALIPER PRESSURE

**2JZ-GE Engine:**

Master cylinder pressure	Rear brake caliper pressure
2,942 kPa (30 kgf/cm <sup>2</sup> , 427 psi)	2,942 kPa (30 kgf/cm <sup>2</sup> , 427 psi)
7,845 kPa (80 kgf/cm <sup>2</sup> , 1,138 psi)	4,756 kPa (48.5 kgf/cm <sup>2</sup> , 690 psi)

**2JZ-GTE Engine:**

Master cylinder pressure	Rear brake caliper pressure
2,452 kPa (25 kgf/cm <sup>2</sup> , 356 psi)	2,452 kPa (25 kgf/cm <sup>2</sup> , 356 psi)
7,845 kPa (80 kgf/cm <sup>2</sup> , 1,138 psi)	4,452 kPa (45.4 kgf/cm <sup>2</sup> , 646 psi)

If the rear brake caliper pressure is incorrect, replace the master cylinder.

### 5. BLEED BRAKE SYSTEM (See page BR-5 )

### 6. CHECK FOR FLUID LEAKAGE

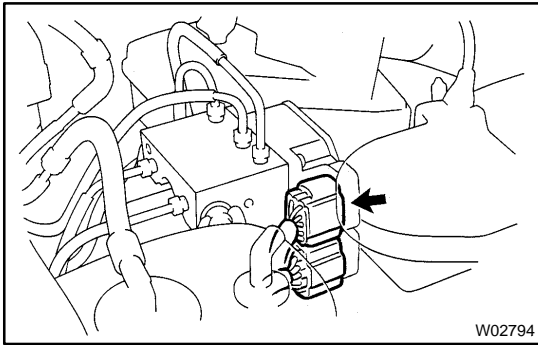

## ABS ACTUATOR (2JZ-GTE) ON-VEHICLE INSPECTION

BR0HT-02

### HINT:

Using the ABS actuator checker (SST), check the operation of the actuator. If the actuator does not operate, check the operation of sub-wire harness G according to instructions on pages [DI-509](#) .. If the solenoid and/or pump motor relay are abnormal, replace the relay and inspect the actuator operation again.

1. **INSPECT BATTERY POSITIVE VOLTAGE**  
**Battery positive voltage: 10-14 V**
2. **DISCONNECT 2 CONNECTORS FROM ACTUATOR**
3. **CONNECT ACTUATOR CHECKER (SST) TO ACTUATOR**
  - (a) Connect the actuator checker (SST) to the actuator side wire harnesses via the sub-wire harnesses (SST), as shown.  
 SST 09990-00150, 09990-00250, 09990-00300, 09990-00360
  - (b) Connect the red cable of the checker to the battery positive (+) terminal and black cable to the negative (-) terminal. Connect the black cable of the sub-wire harnesses to the battery negative (-) terminal or body ground.

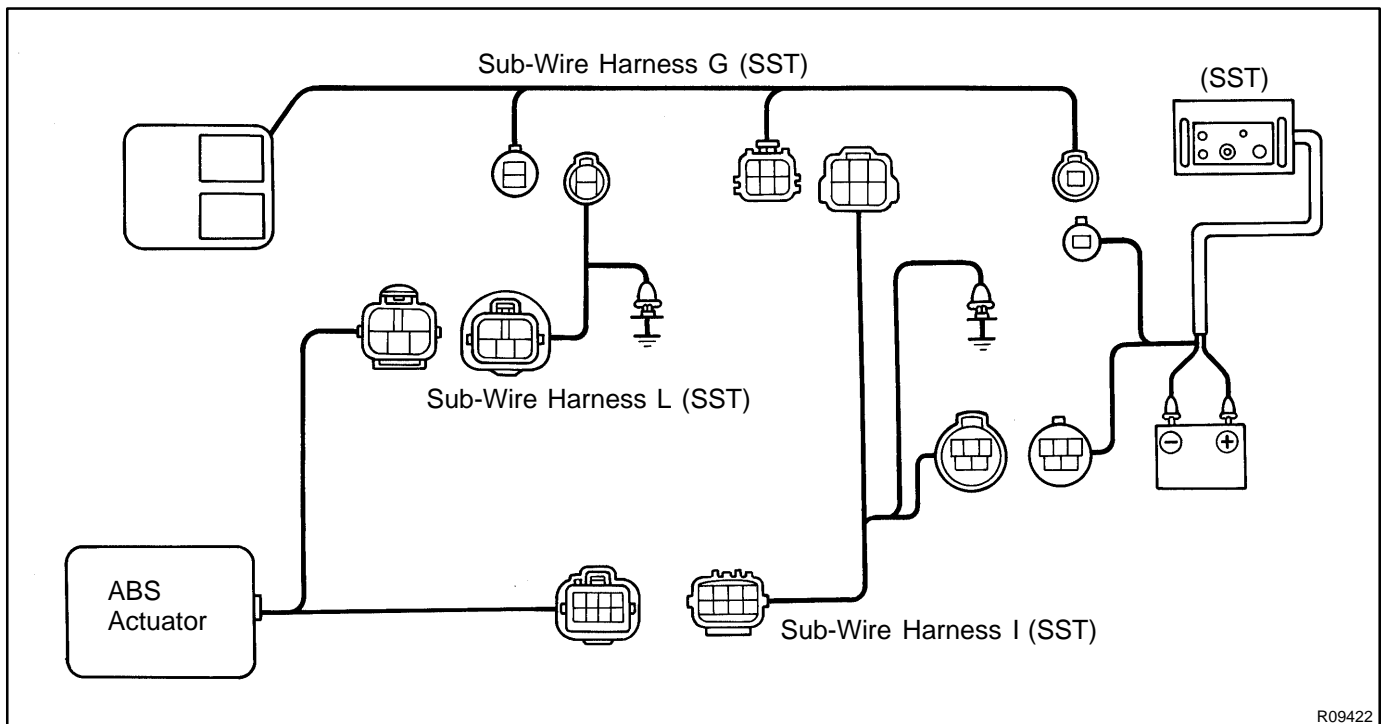

- (c) Place the "SHEET N" (SST) on the actuator checker.  
SST 09990-00410

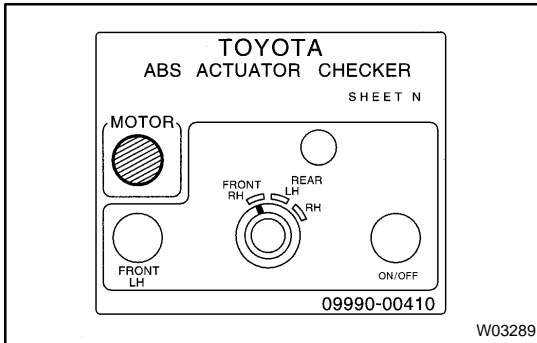

#### 4. INSPECT BRAKE ACTUATOR OPERATION OF FRONT LH WHEEL

- (a) Start the engine, and run it at idle.  
(b) Turn the selector switch of the actuator checker to "FRONT RH" position.  
(c) Push and hold in the MOTOR switch for a few seconds. Make sure that you can hear the motor running.  
(d) Depress the brake pedal and hold it for about 15 seconds, and check that the pedal does not go down.

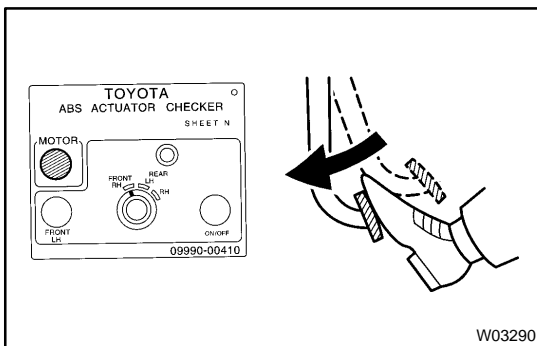

- (e) With your foot still applying onto the brake pedal, push MOTOR switch and check that the brake pedal does not pulsate.

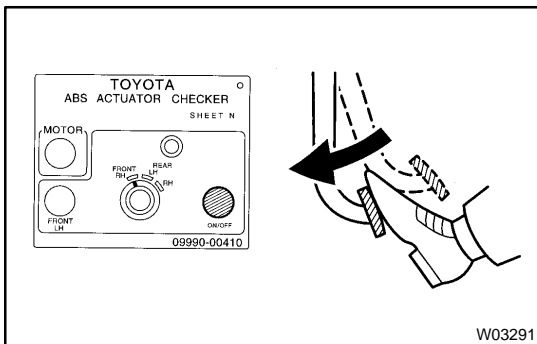

- (f) Depress the brake pedal and hold it. As you hold the pedal down, push and hold in the MAIN push switch for a few seconds. Check that the pedal does not go down.

#### NOTICE:

**Do not keep pushing the MAIN push switch more than 10 seconds.**

- (g) With your foot still applying onto the brake pedal, release the MAIN push switch and check that the pedal goes down.

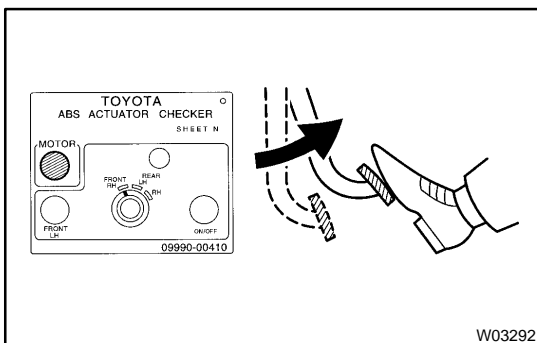

- (h) With your foot still applying onto the brake pedal, push the MOTOR switch and check that the brake pedal returns.

- (i) Release the brake pedal.

#### 5. INSPECT FOR OTHER WHEEL

- (a) Turn the selector switch to the "REAR LH" position, and inspect the "REAR LH" wheel.

- (b) Repeating (c) to (i) in the step 4, check the actuator operation similarly.

(c) Similarly, inspect the "REAR RH" and "FRONT RH" wheel.

HINT:

When inspecting the "FRONT RH" wheel, push the FRONT LH switch instead of the MAIN push switch. This makes it possible to inspect wherever the selector switch position indicates.

**6. PUSH MOTOR SWITCH**

- (a) Push and hold in the MOTOR switch for a few seconds.
- (b) Stop the engine.

**7. DISCONNECT ACTUATOR CHECKER (SST) FROM ACTUATOR**

- (a) Disconnect the actuator checker (SST) and sub-wire harnesses (SST) from the actuator.

SST 09990-00150, 09990-00250, 09990-00300,  
09990-00360, 09990-00410

- (b) Connect the 2 actuator connectors.
- (c) Clear the DTC (See page [DI-442](#) ).



# COMPONENTS

## NORMAL ABS :

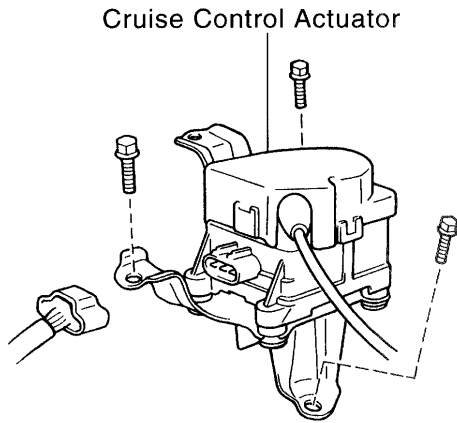

## SPORT ABS :

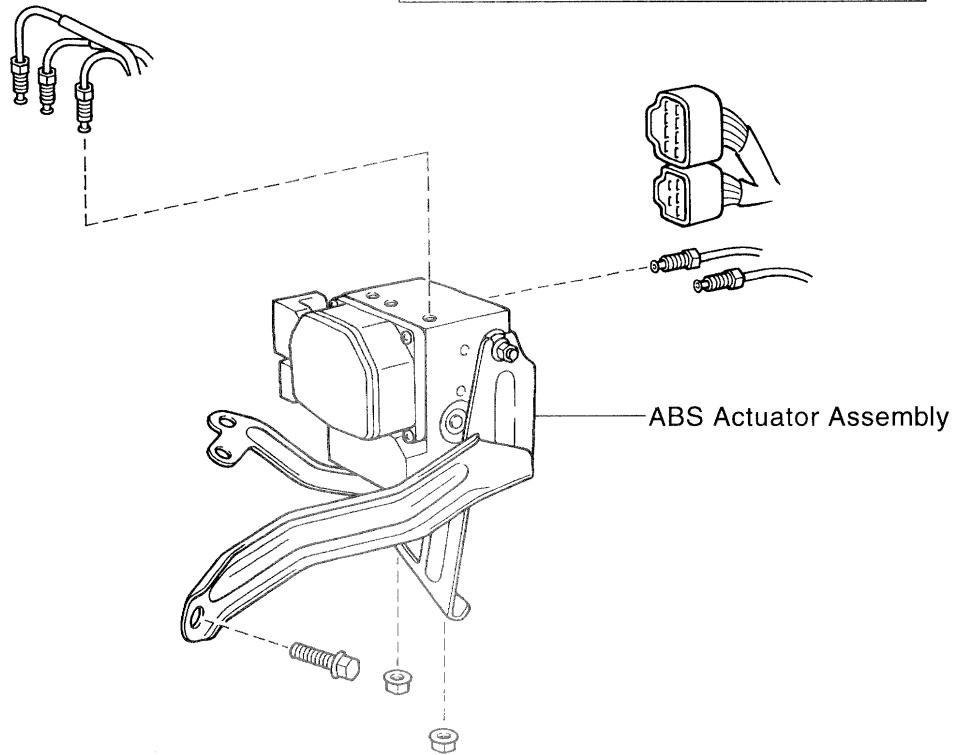
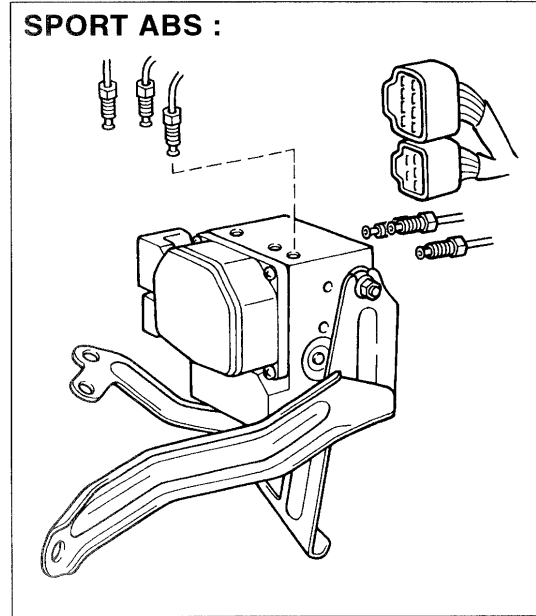

W02804

W02804

**SPORT ABS:**

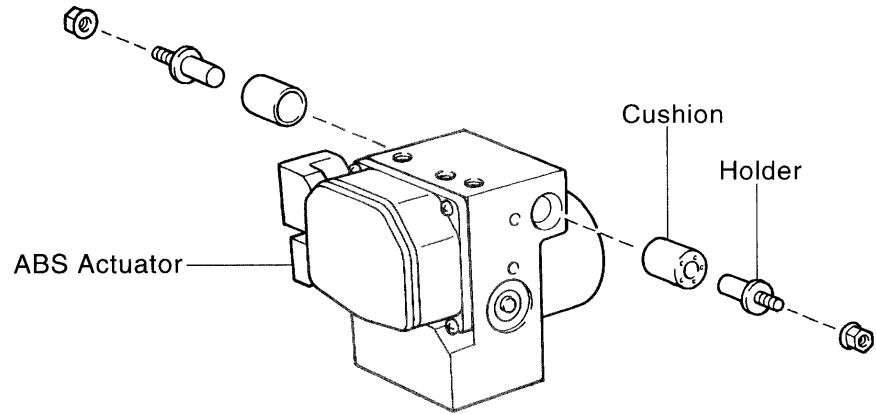

**NORMAL ABS:**

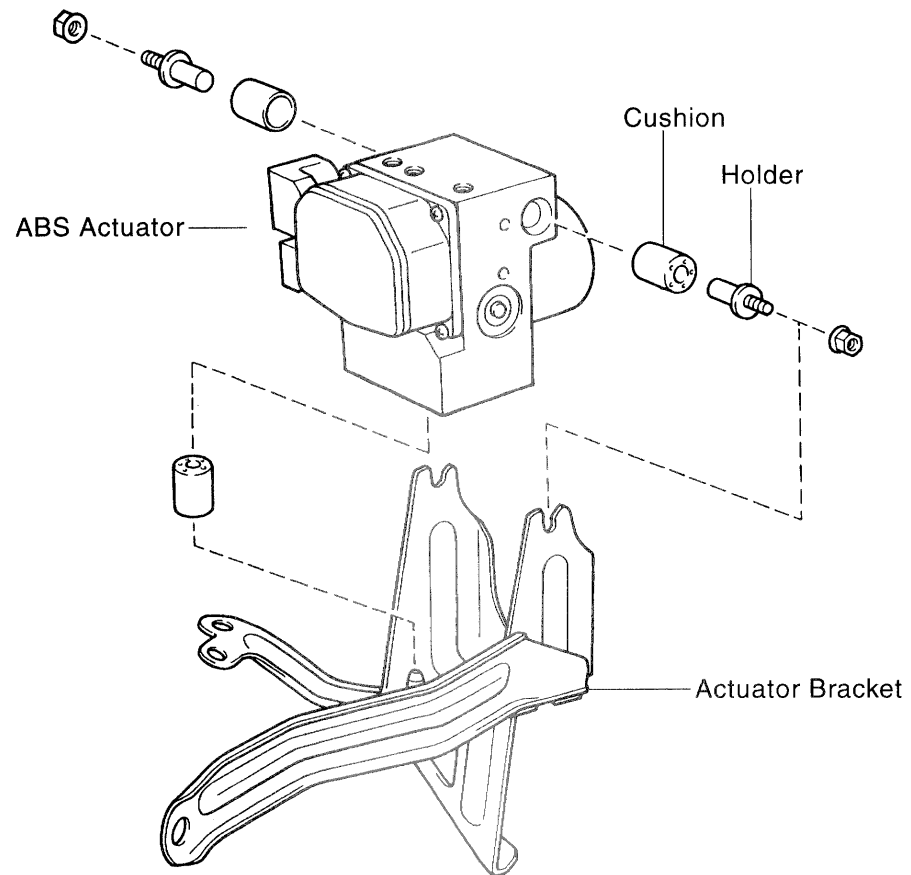

V02895

## REMOVAL

### 1. REMOVE CRUISE CONTROL ACTUATOR

- (a) Disconnect the connector from the cruise control actuator.
- (b) Remove the 3 bolts and cruise control actuator.  
**Torque: 19 N·m (195 kgf-cm, 14 ft-lbf)**

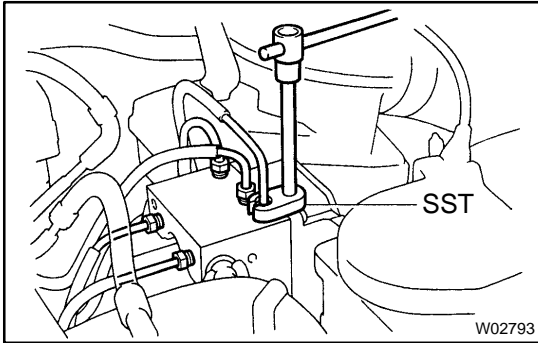

### 2. DISCONNECT BRAKE LINES

Using SST, disconnect the 6 brake lines from the ABS actuator.  
SST 09023-00100

**Torque: 15 N·m (155 kgf-cm, 11 ft-lbf)**

### 3. DISCONNECT CONNECTORS

Disconnect the 2 connectors and wire harness clamp from the bracket.

### 4. REMOVE ABS ACTUATOR ASSEMBLY

Remove the bolt, 2 nuts and ABS actuator assembly.

**Torque: 19 N·m (195 kgf-cm, 14 ft-lbf)**

### 5. REMOVE ABS ACTUATOR

- (a) Remove the 2 nuts and actuator from bracket.  
**Torque: 5.4 N·m (55 kgf-cm, 48 in.-lbf)**
- (b) Remove the 2 cushion bolts and 3 cushions.

# FRONT SPEED SENSOR COMPONENTS

BR0HX-02

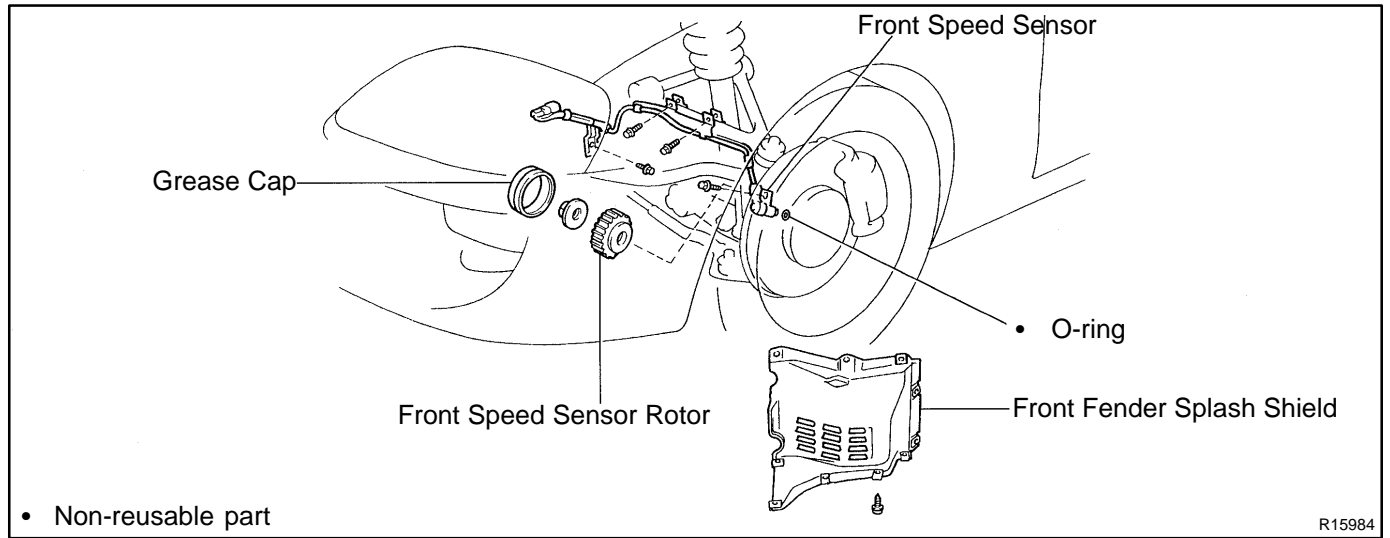

R15984

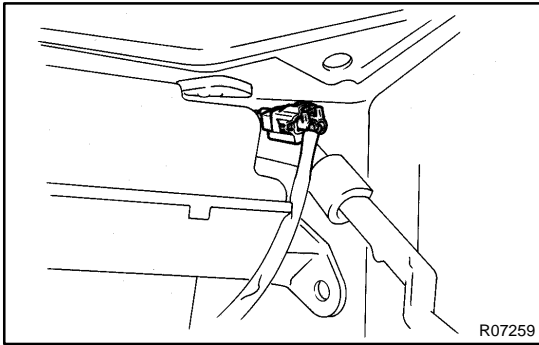

## REMOVAL

### 1. DISCONNECT CONNECTOR

- (a) Remove the front fender splash shield.
- (b) Disconnect the speed sensor connector.

### 2. REMOVE SPEED SENSOR

- (a) Remove the 3 clamp bolts holding the sensor harness to the body and upper suspension arm.

**Torque: 5.4 N·m (55 kgf·cm, 48 in.-lbf)**

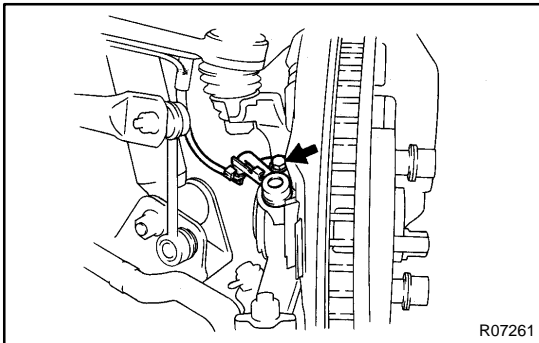

- (b) Remove the speed sensor from the steering knuckle.

**Torque: 7.8 N·m (80 kgf·cm, 69 in.-lbf)**

- (c) Remove the O-ring from the speed sensor.

# REAR SPEED SENSOR COMPONENTS

BR010-02

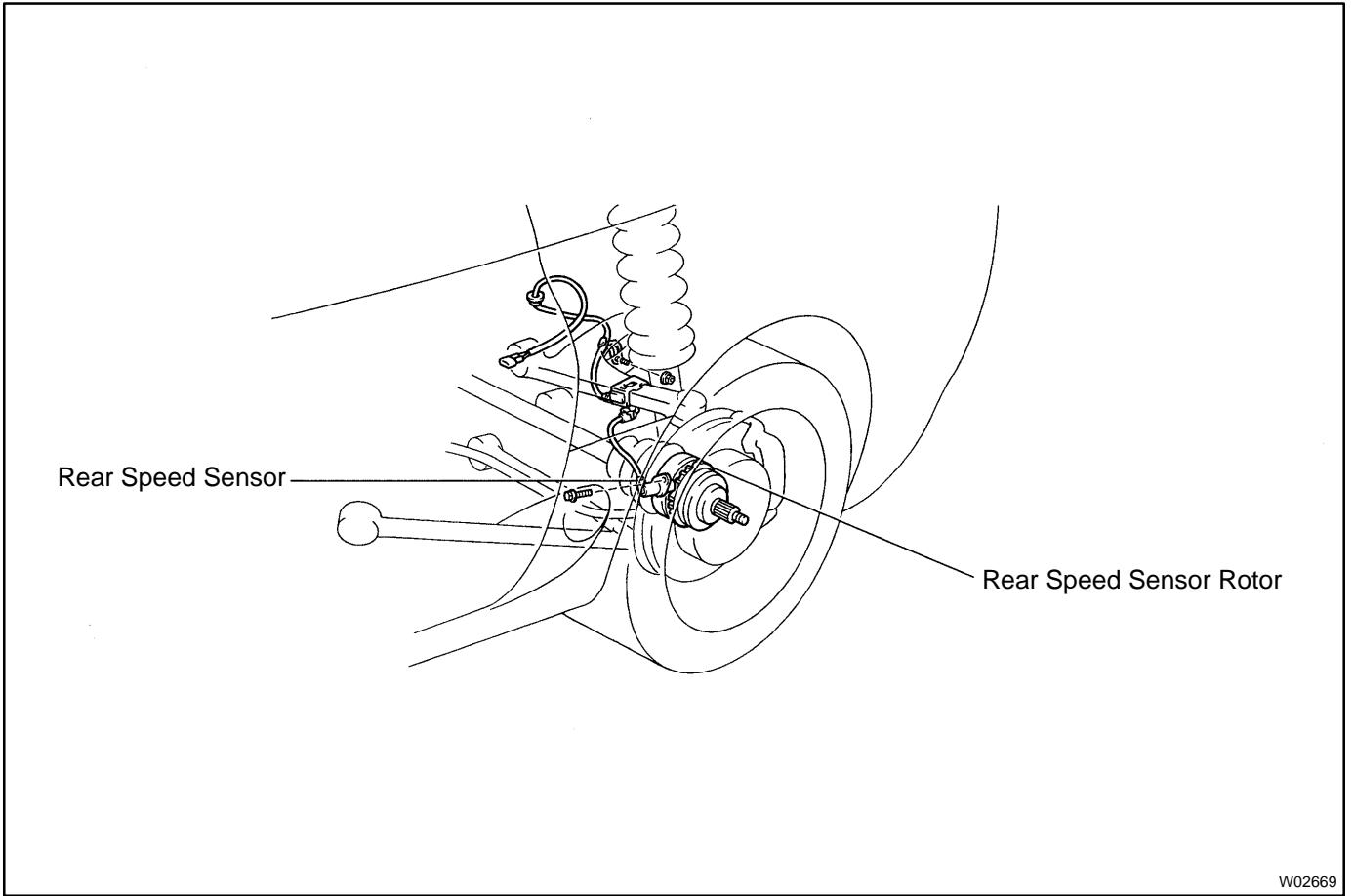

W02669

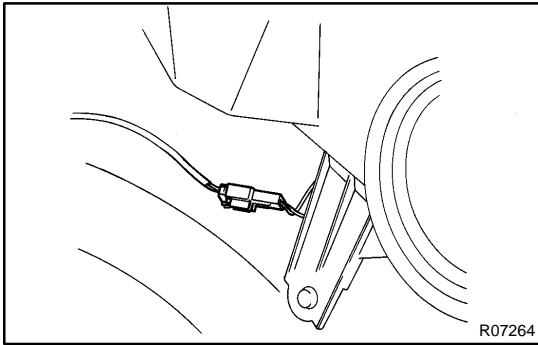

## REMOVAL

### 1. DISCONNECT SPEED SENSOR CONNECTOR

- (a) Remove the rear seat cushion and seatback.
- (b) Remove the quarter trim panel.
- (c) Disconnect the speed sensor connector, and pull out the sensor wire harness with the grommet.

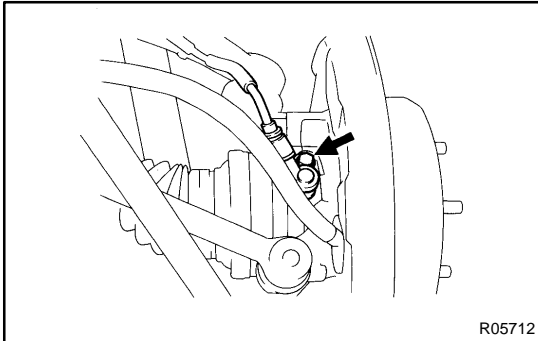

### 2. REMOVE SPEED SENSOR

- (a) Remove the nut holding the sensor wire harness to the body.

**Torque: 5.4 N·m (55 kgf·cm, 48 in.-lbf)**

- (b) Remove the clamp from the upper arm.
- (c) Remove the speed sensor from the axle carrier.

**Torque: 7.8 N·m (80 kgf·cm, 69 in.-lbf)**