

TROUBLESHOOTING

SR13T-01

PROBLEM SYMPTOMS TABLE

Use the table below to help you find the cause of the problem. The numbers indicate the priority of the likely cause of the problem. Check each part in order. If necessary, repair or replace these parts.

Symptom	Suspect Area	See page
Hard steering	<ol style="list-style-type: none"> 1. Tires (Improperly inflated) 2. Power steering fluid level (Low) 3. Drive belt (Loose) 4. Front wheel alignment (Incorrect) 5. Steering system joints (Worn) 6. Suspension arm ball joints (Worn) 7. Steering column (Binding) 8. Power steering gear 9. PPS system 	<p>SA-2 SR-4 - SA-3 - SA-30 SA-35 - - SR-54</p>
Poor return	<ol style="list-style-type: none"> 1. Tires (Improperly inflated) 2. Front wheel alignment (Incorrect) 3. Steering column (Binding) 4. Power steering gear 	<p>SA-2 SA-3 - -</p>
Excessive play	<ol style="list-style-type: none"> 1. Steering system joints (Worn) 2. Suspension arm ball joints (Worn) 3. Intermediate shaft, Universal joint, Sliding yoke (Worn) 4. Front wheel bearing (Worn) 5. Power steering gear 6. PPS system 	<p>- SA-30 SA-35 - SA-12 - SR-54</p>
Abnormal noise	<ol style="list-style-type: none"> 1. Power steering fluid level (Low) 2. Steering system joints (Worn) 3. Power steering gear 	<p>SR-4 - -</p>

POWER STEERING FLUID BLEEDING

SR13U-01

1. **CHECK FLUID LEVEL**
(See page [SR-4](#))
2. **JACK UP FRONT OF VEHICLE AND SUPPORT IT WITH STANDS**
3. **TURN STEERING WHEEL**

With the engine stopped, turn the steering wheel slowly from lock to lock several times.

NOTICE:

Take care that some fluid remains in the oil reservoir.

4. **LOWER VEHICLE**
5. **START ENGINE**

Run the engine at idle for a few minutes.

6. **TURN STEERING WHEEL**

(a) With the engine at idling, turn the steering wheel to left or right full lock and keep it there for 2-3 seconds, then turn the wheel to the opposite full lock and keep it there for 2-3 seconds.

(b) Repeat (a) several times.

7. **STOP ENGINE**

8. **CHECK FOR FOAMING OR EMULSIFICATION**

If the system has to be bled twice specifically because of foaming or emulsification, check for fluid leaks in the system.

9. **CHECK FLUID LEVEL**
(See page [SR-4](#))

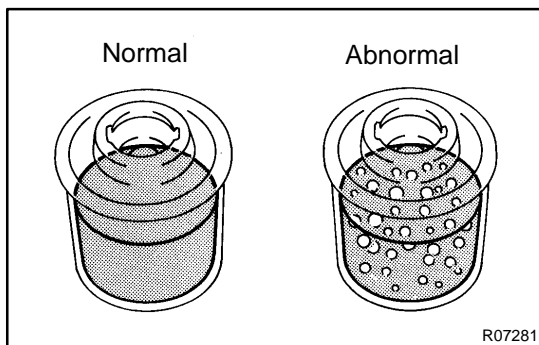

R07281

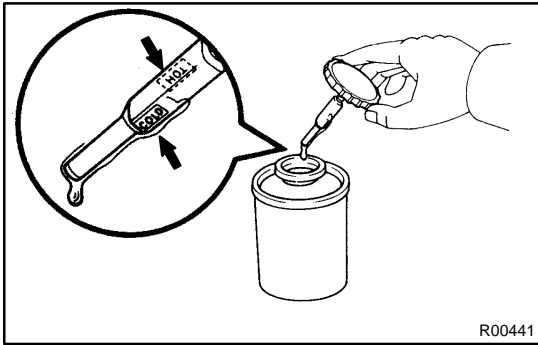

INSPECTION

1. CHECK FLUID LEVEL

- (a) Keep the vehicle level.
With the engine stopped, check the fluid level in the oil reservoir.

If necessary, add fluid.

Fluid: ATF DEXRON® II or III

HINT:

Check that the fluid level is within the HOT LEVEL range on the dipstick of the reservoir cap. If the fluid is cold, check that it is within the COLD LEVEL range.

- (b) Start the engine and run it at idle.
- (c) Turn the steering wheel from lock to lock several times to boost fluid temperature.

Fluid temperature: 80°C (176°F)

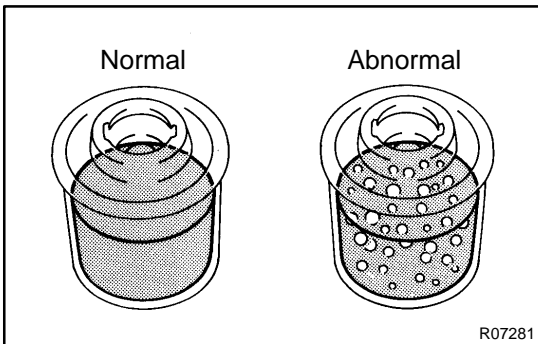

- (d) Check for foaming or emulsification.
If there is foaming or emulsification, bleed power steering system.

(See page [SR-3](#))

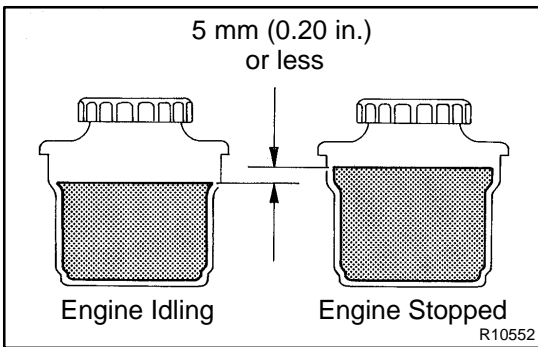

- (e) With the engine idling, measure the fluid level in the oil reservoir.

- (f) Stop the engine.

- (g) Wait a few minutes and remeasure the fluid level in the reservoir.

Maximum fluid level rise: 5mm (0.20 in.)

If a problem is found, bleed power steering system.

(See page [SR-3](#))

- (h) Check the fluid level.

2. CHECK STEERING FLUID PRESSURE

- (a) Disconnect the pressure feed tube from the PS vane pump.

(See page [SR-26](#))

- (b) Connect SST over a new gasket, as shown below.

SST 09640-10010 (09641-01010, 09641-01030, 09641-01060)

NOTICE:

Check that the valve of the SST is in the open position.

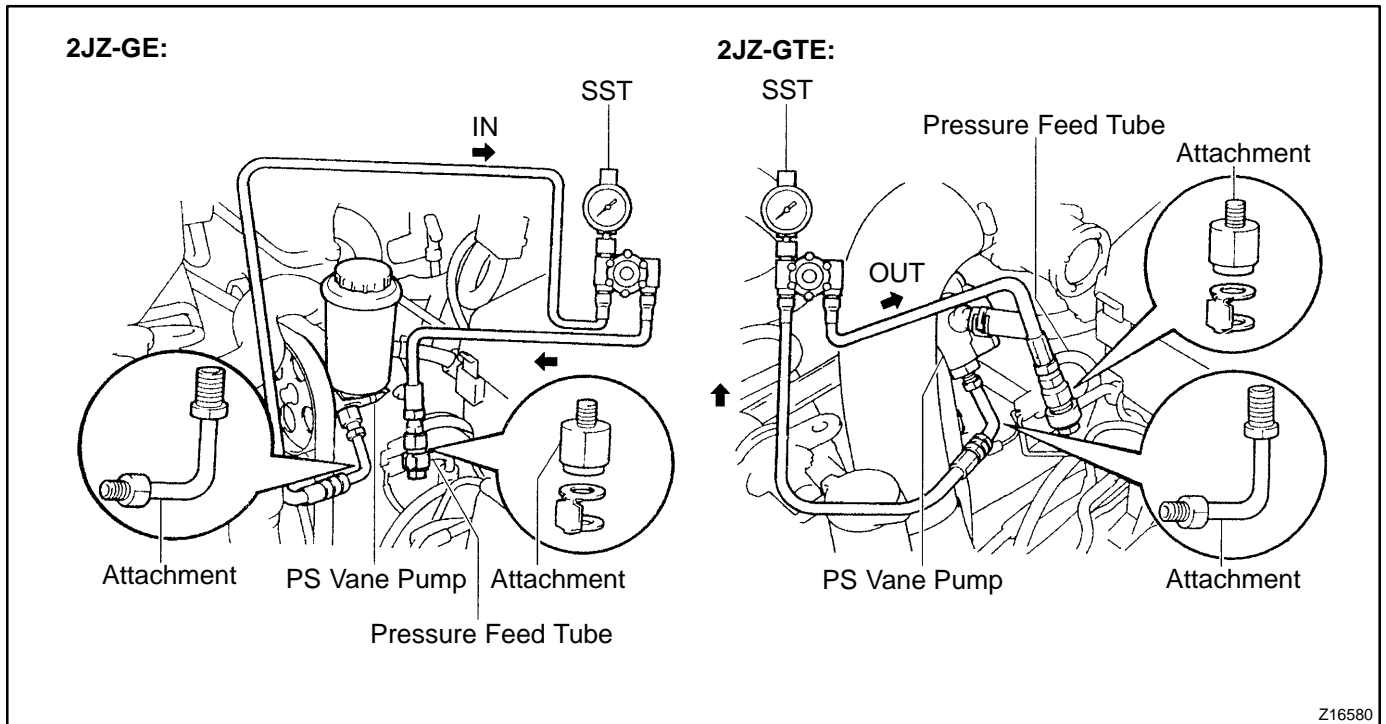

- (c) Bleed the power steering system.

(See page [SR-3](#))

- (d) Start the engine and run it at idle.

- (e) Turn the steering wheel from lock to lock several times to boost fluid temperature.

Fluid temperature: 80°C (176°F)

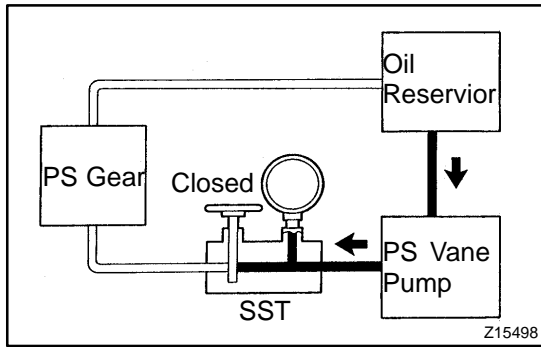

- (f) With the engine idling, close the valve of the SST and observe the reading on the SST.
Minimum fluid pressure:
7,355 kPa (75 kgf.cm², 1,067 psi)

NOTICE:

- ◆ Do not keep the valve closed for more than 10 seconds.
- ◆ Do not let the fluid temperature become too high.

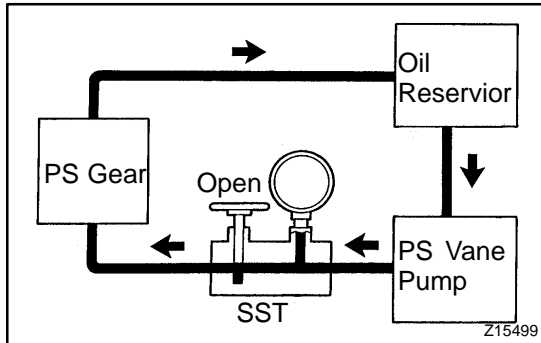

- (g) With the engine idling, open the valve fully.
 (h) Measure the fluid pressure at engine speeds of 1,000 rpm and 3,000 rpm.

Difference fluid pressure:
490 kPa (5 kgf.cm², 71 psi) or less

NOTICE:

Do not turn the steering wheel.

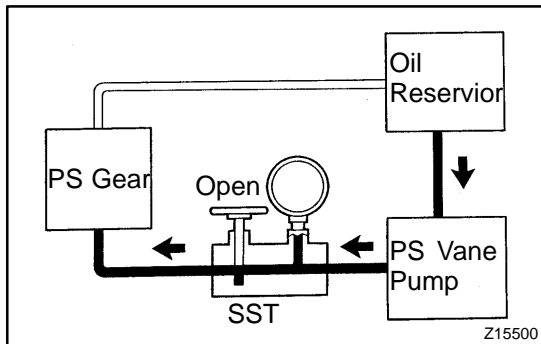

- (i) With the engine idling and valve fully opened, turn the wheel to full lock.
Minimum fluid pressure:
7,355 kpa (75 kgf,cm², 1,067 psi)

NOTICE:

- ◆ Do not maintain lock position for more than 10 seconds.
- ◆ Do not let the fluid temperature become too high.

- (j) Disconnect the SST.
 (k) Connect the pressure feed tube.
 (See page [SR-34](#))
 (l) Bleed the power steering system.
 (See page [SR-3](#))

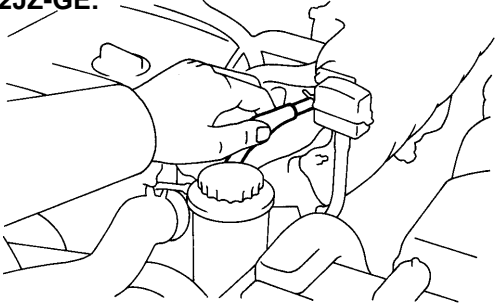
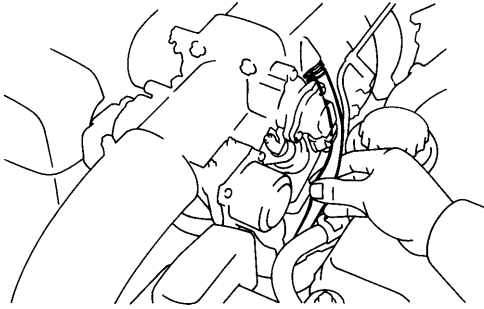
2JZ-GE:**2JZ-GTE:**

Z13450

AIR CONTROL VALVE INSPECTION

SR0CK-01

CHECK IDLE-UP

- (a) Turn the air conditioner switch off.
- (b) Start the engine and run it at idle.
- (c) Fully turn the steering wheel.
- (d) Check that the engine speed decreases when the vacuum hose of the air control valve is pinched.
- (e) Check that the engine speed increases when the hose is released.

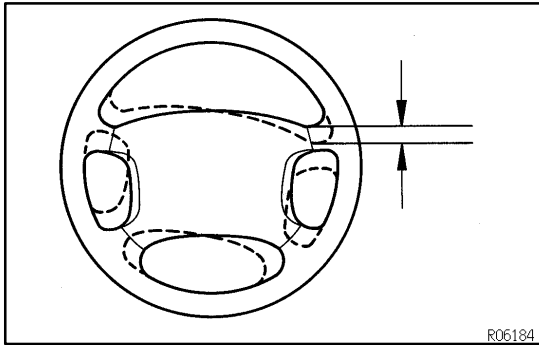

STEERING WHEEL INSPECTION

SR13W-01

1. CHECK STEERING WHEEL FREEPLAY

With the vehicle stopped and tires pointed straight ahead, rock the steering wheel gently back and forth with light finger pressure.

Freeplay should not exceed the maximum.

Maximum freeplay: 30 mm (1.18 in.)

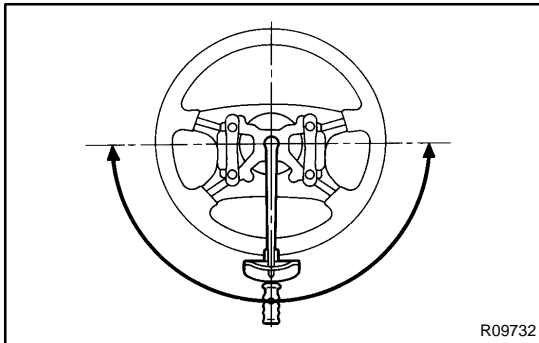

2. CHECK STEERING EFFORT

- (a) Center the steering wheel.
- (b) Remove the steering wheel pad.
(See page [SR-1 1](#))
- (c) Start the engine and run it at idle.
- (d) Measure the steering effort in both directions.

Reference (Maximum): 6.9 N·m (70 kgf·cm, 61 in.-lbf)

If steering effort is excessive, repair the power steering unit.

HINT:

Be sure to consider the tire type, pressure and contact surface before making your diagnosis.

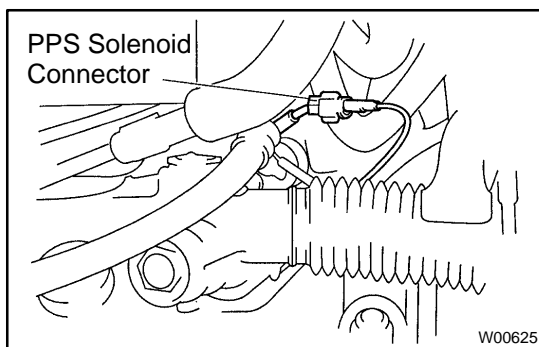

- (e) Disconnect the PPS solenoid connector.
- (f) Measure the steering effort in both directions and check that the steering effort exceeds the reference value in (d), and that the power assist is operating.

If steering effort is not heavier than (d), check the solenoid.

- (g) Connect the connector.
- (h) Torque the steering wheel set nut.

Torque: 35 N·m (360 kgf·cm, 26 ft·lbf)

- (i) Install the steering wheel pad.
(See page [SR-21](#))

TILT STEERING COLUMN COMPONENTS

SR13X-01

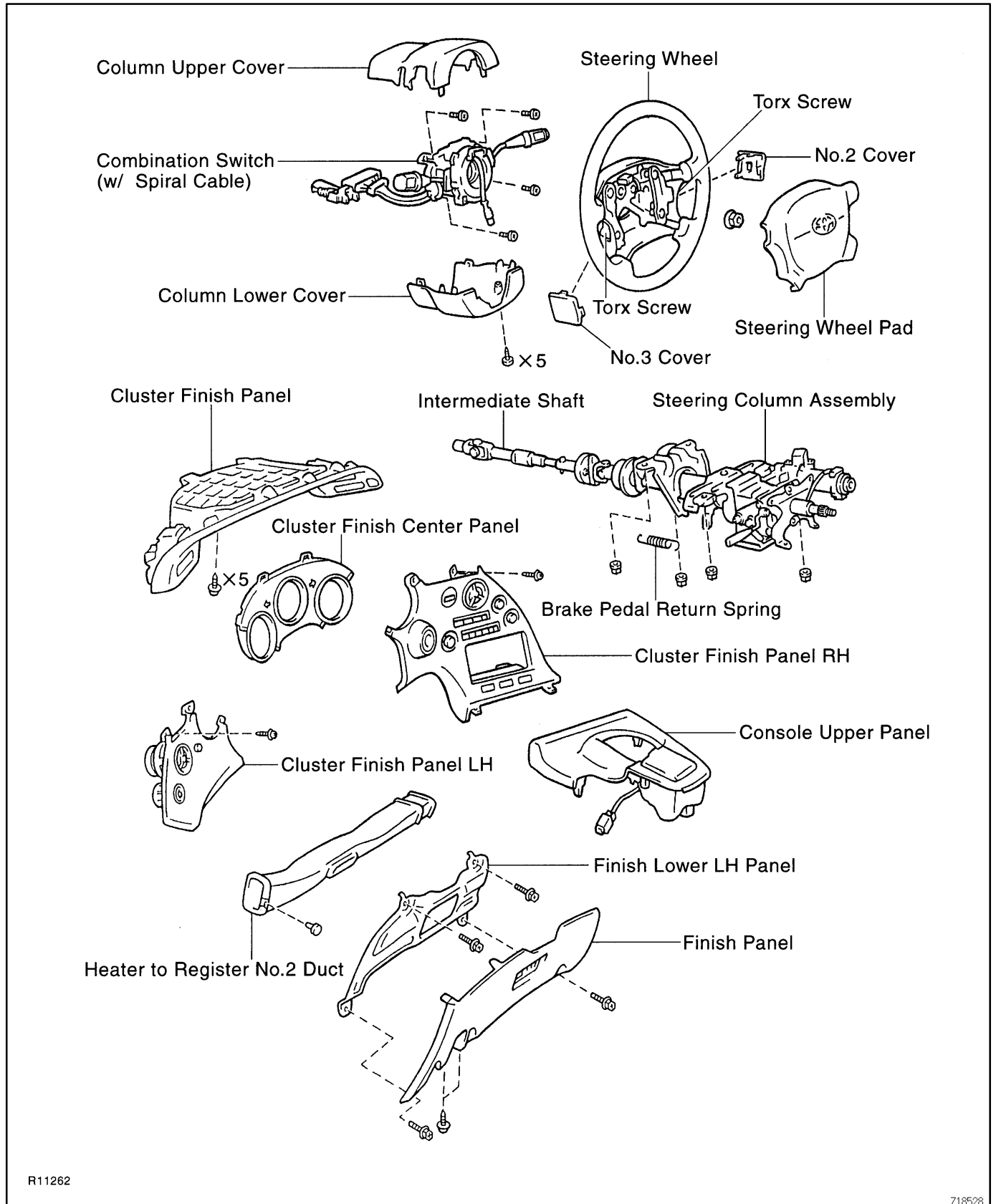

R11262

Z18528

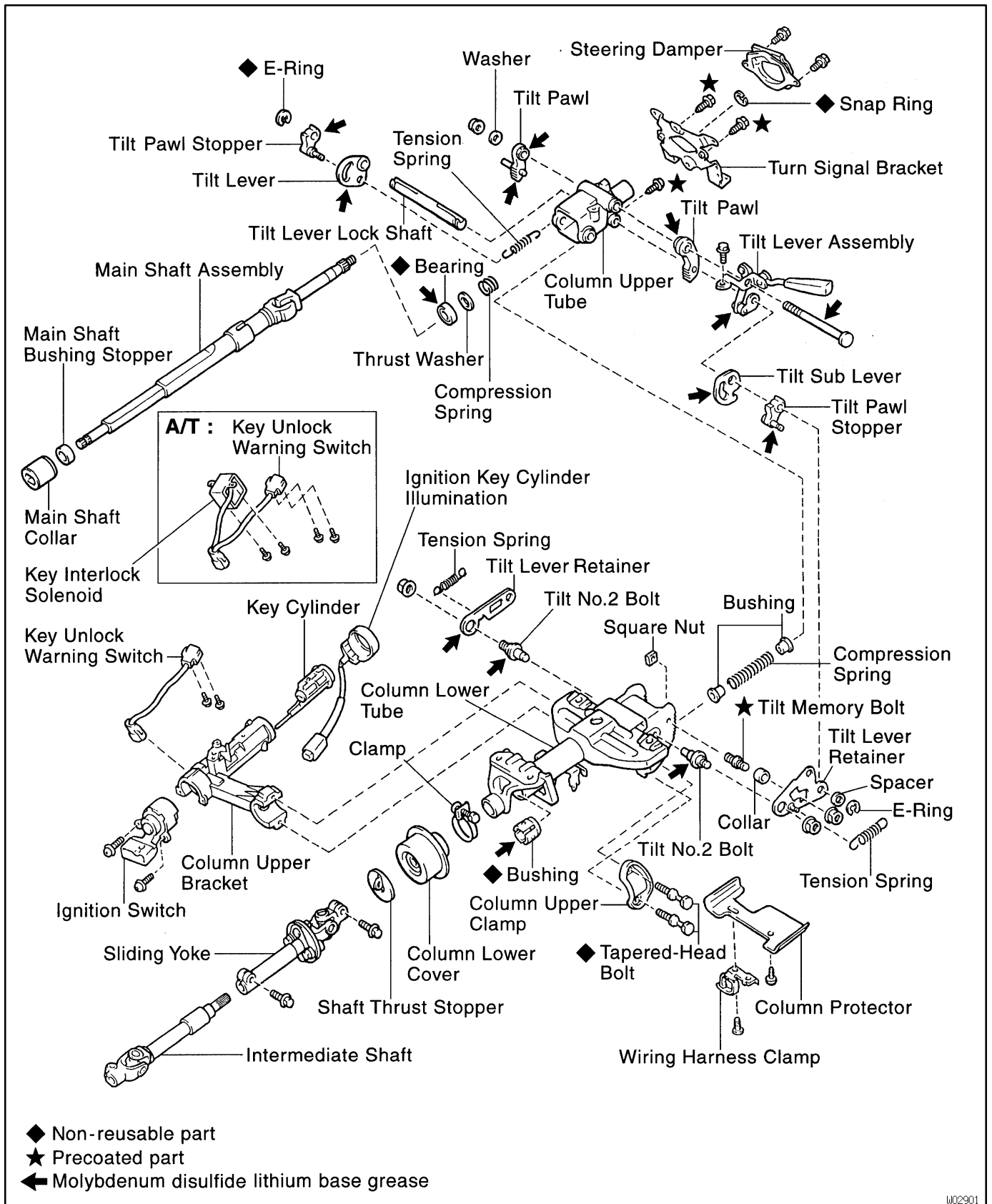

W02901

REMOVAL

1. REMOVE STEERING WHEEL PAD

NOTICE:

If the airbag connector is disconnected with the ignition switch at ON or ACC, DTCs will be recorded. Never use airbag parts from another vehicle. When replacing parts, replace with new parts.

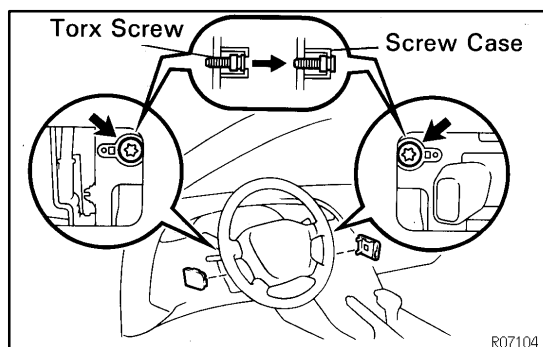

- Place the front wheels facing straight ahead.
- Using a torx socket wrench, loosen the 2 torx screws.

HINT:

Loosen the 2 screws until the groove along the screw circumference catches on the screw case.

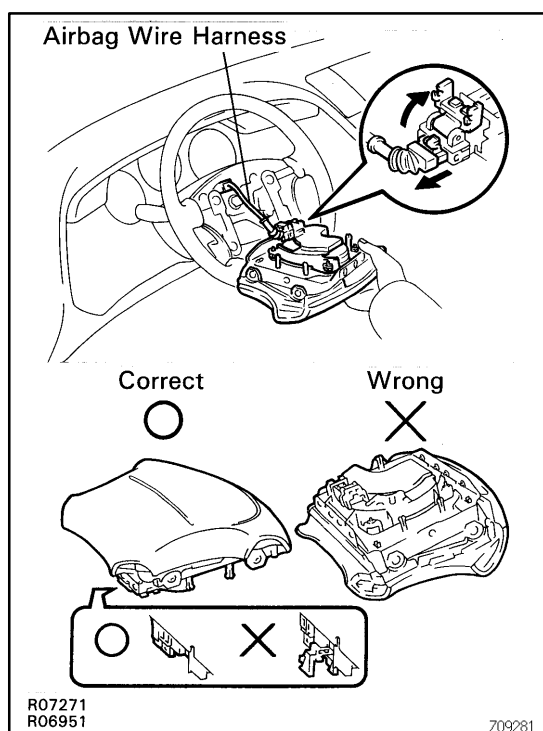

- Pull the pad out from the steering wheel and disconnect the airbag connector.

CAUTION:

When storing the pad, keep the upper surface of the pad facing upward. Never disassemble the pad.

NOTICE:

When removing the pad, take care not to pull the airbag wire harness.

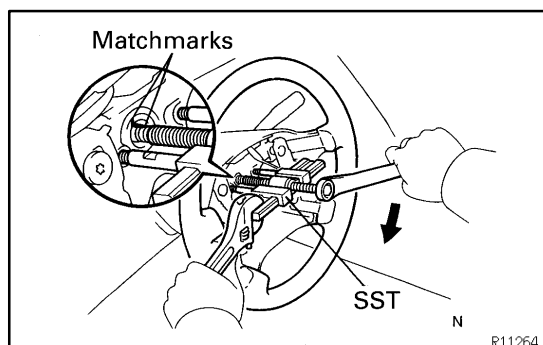

2. REMOVE STEERING WHEEL

- Disconnect the connector.
- Remove the wheel set nut.
- Place matchmarks on the wheel and main shaft.
- Using SST, remove the wheel.

SST 09950-50010 (09951-05010, 09952-05010, 09953-05020, 09954-05020)

3. REMOVE UPPER AND LOWER COLUMN COVERS

Remove 5 screws.

4. REMOVE THESE PARTS:**(See page BO-54)**

- (a) Console upper panel
- (b) Cluster finish panel
- (c) Cluster finish panel RH
- (d) Cluster finish panel LH
- (e) Cluster finish center panel
- (f) Finish panel
- (g) Finish lower LH panel
- (h) Heater to register No.2 duct

5. REMOVE COMBINATION SWITCH WITH SPIRAL CABLE

- (a) Remove the 4 screws.
- (b) Disconnect the connectors and airbag connector.

6. REMOVE SPIRAL CABLE**(See page BE-16)****NOTICE:****Do not disassemble the cable or apply oil to it.****7. DISCONNECT INTERMEDIATE SHAFT**

- (a) Place matchmarks on the intermediate shaft and control valve shaft.
- (b) Loosen bolt B and remove bolt A.

8. REMOVE STEERING COLUMN ASSEMBLY

- (a) Remove the brake pedal return spring.
- (b) Disconnect the connectors.
- (c) Loosen the hole cover clamp.
- (d) Remove the 4 column assembly set nuts.

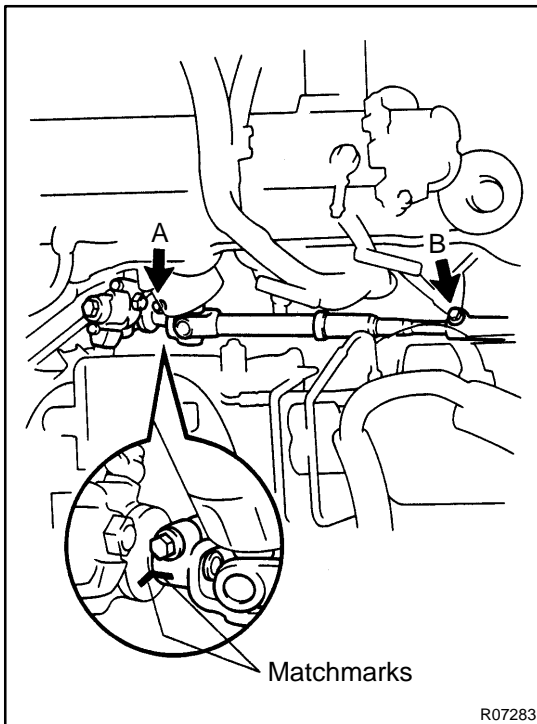

DISASSEMBLY

NOTICE:

When using a vise, do not overtighten it.

1. REMOVE IGNITION KEY CYLINDER ILLUMINATION
2. REMOVE INTERMEDIATE SHAFT

Remove the bolt.

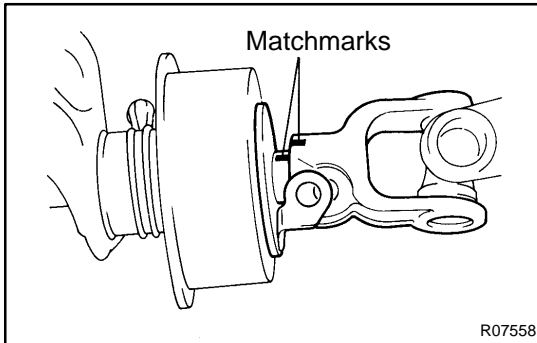

3. REMOVE SLIDING YOKE AND SHAFT THRUST STOPPER

- (a) Remove the bolt.
- (b) Shift the stopper.
- (c) Place matchmarks on the sliding yoke and main shaft.

4. REMOVE COLUMN LOWER COVER

Loosen the clamp.

5. REMOVE COLUMN UPPER BRACKET AND COLUMN UPPER CLAMP

- (a) Using a centering punch, mark the center of the 2 tapered-head bolts.
- (b) Using a 4 - 5 mm (0.16 - 0.20 in.) drill, drill into the 2 tapered-head bolts.

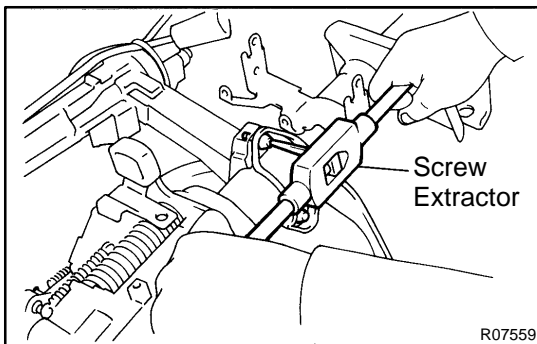

- (c) Using a screw extractor, remove the 2 tapered-head bolts.

6. REMOVE WIRING HARNESS CLAMP AND COLUMN PROTECTOR

Remove the 2 screws.

7. REMOVE COMPRESSION SPRING

- (a) Using a torx socket wrench, remove the screw.
- (b) Remove the 2 bushings from the spring.

8. REMOVE 3 TENSION SPRINGS

9. REMOVE STEERING DAMPER

Remove the 2 bolts.

10. REMOVE TURN SIGNAL BRACKET

Remove the 2 bolts.

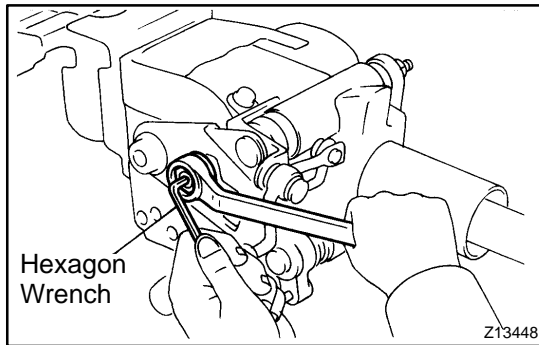

**11. Tilt Lever Side:
REMOVE TILT LEVER RETAINER**

Remove the nut and E-ring.

**12. Tilt Sub Lever Side:
REMOVE TILT LEVER RETAINER**

- (a) Using a hexagon wrench (4 mm) to hold the tilt memory bolt, remove the nut.
- (b) Remove the nut, washer and bolt.
- (c) Remove the nut, E-ring and spacer.
- (d) Remove the collar.
- (e) Temporarily install the bolt, washer and nut.

13. REMOVE 2 TILT PAWL STOPPERS

14. REMOVE 2 TILT PAWLS

- (a) Remove the bolt, nut and washer.
- (b) Remove the tilt lever assembly set bolt.

15. REMOVE TILT LEVER, TILT SUB LEVER, TILT LEVER ASSEMBLY AND TILT LEVER LOCK SHAFT

16. REMOVE TILT MEMORY BOLT AND SQUARE NUT

Using a hexagon wrench (4 mm), remove the bolt.

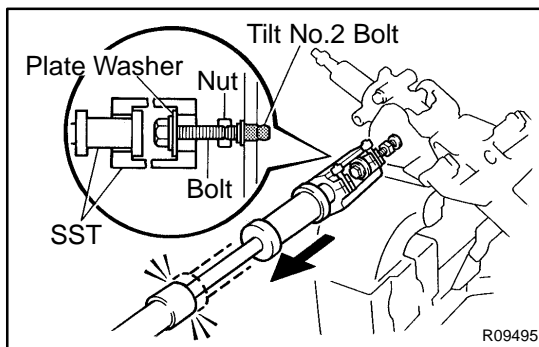

17. REMOVE COLUMN UPPER TUBE WITH MAIN SHAFT ASSEMBLY

- (a) Set SST, the nut (10 mm nominal diameter, 1.25 mm pitch), plate washer (36 mm outer diameter) and bolt (10 mm nominal diameter, 1.25 mm pitch, 50 mm length) to the tilt No.2 bolt, as shown.

SST 09910-00015 (09911-0001 1, 09912-00010)

Reference:

Nut 90170-10004

Plate washer 90201-10201

Bolt 91111-51050

- (b) Remove the 2 tilt No.2 bolts by using the sliding hammer on SST.
- (c) Remove the upper tube with the shaft assembly from the column lower tube.

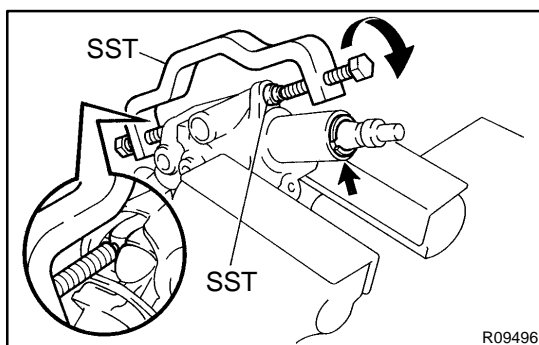

18. REMOVE MAIN SHAFT ASSEMBLY

- (a) Using SST, compress the compression spring.
SST 09950-40010 (09957-04010, 09958-04010)

NOTICE:

Do not bend the universal joint of the main shaft assembly more than 20°.

- (b) Using a snap ring expander, remove the snap ring.
- (c) Remove the main shaft assembly from the upper tube.
- (d) Remove the compression spring, thrust collar and bearing from the main shaft.

19. REMOVE MAIN SHAFT COLLAR AND MAIN SHAFT BUSHING STOPPER

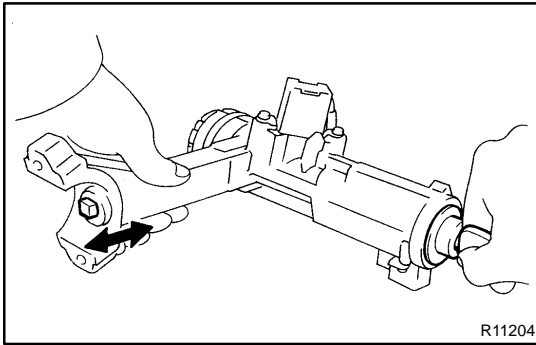

INSPECTION

1. INSPECT COLUMN UPPER BRACKET

Check that the steering lock mechanism operates properly.

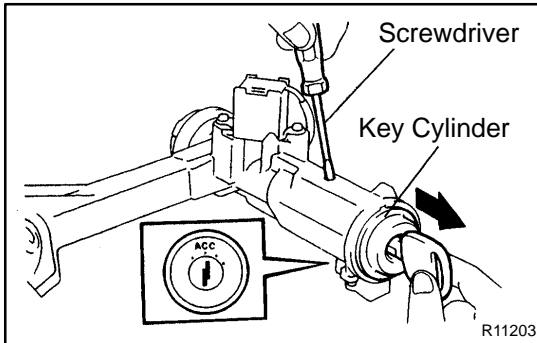

2. IF NECESSARY, REPLACE KEY CYLINDER

- Place the ignition key at the ACC position.
- Push down the stop pin with a screwdriver and pull out the key cylinder.
- Install a new key cylinder.

HINT:

Make sure the ignition key is at the ACC position.

3. INSPECT IGNITION SWITCH

(See page [BE-13](#))

4. IF NECESSARY, REPLACE IGNITION SWITCH

- Remove the 2 screws.
- Install new switch with the 2 screws.

5. INSPECT KEY UNLOCK WARNING SWITCH

(See page [BE-13](#))

6. A/T:

INSPECT KEY INTERLOCK SOLENOID

(See page [AT-17](#), [AT-15](#))

7. IF NECESSARY, REPLACE KEY UNLOCK WARNING SWITCH

- Remove the 2 screws.
- Install a new switch with the 2 screws.

8. A/T:

IF NECESSARY, REPLACE KEY INTERLOCK SOLENOID WITH KEY UNLOCK WARNING SWITCH

- Remove the 4 screws.
- Install a new solenoid and warning switch with the 4 screws.

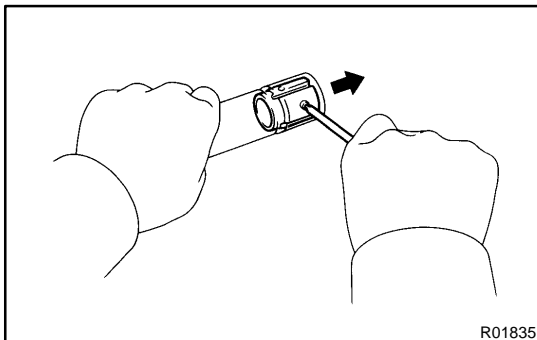

9. IF NECESSARY, REPLACE BUSHING

- Using a screwdriver, depress the 3 projections on the bushing and remove the bushing from the column lower tube.
- Align the projections on a new bushing with the holes in the lower tube. Install the bushing until the projections are firmly engaged in the holes in the lower tube.

REASSEMBLY

NOTICE:

When using a vise, do not overtighten it.

1. **COAT MOLYBDENUM DISULFIDE LITHIUM BASE GREASE**
(See page [SR-9](#))
2. **INSTALL MAIN SHAFT BUSHING STOPPER AND MAIN SHAFT COLLAR**

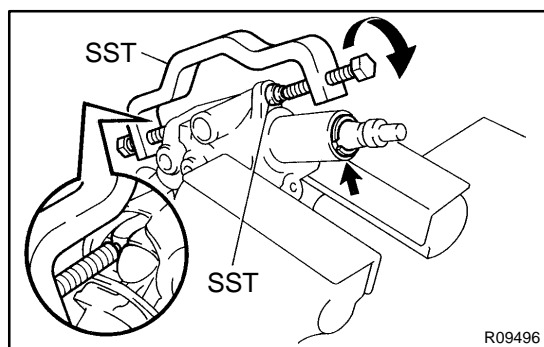

3. INSTALL MAIN SHAFT ASSEMBLY

- (a) Install a new bearing.
- (b) Install the thrust collar and compression spring to the shaft assembly.
- (c) Install the main shaft into the column upper tube.
- (d) Using SST, compress the compression spring.
SST 09950-40010 (09957-04010, 09958-04010)

NOTICE:

Do not bend the universal joint of the main shaft assembly more than 20°.

- (e) Using a snap ring expander, install a new snap ring.

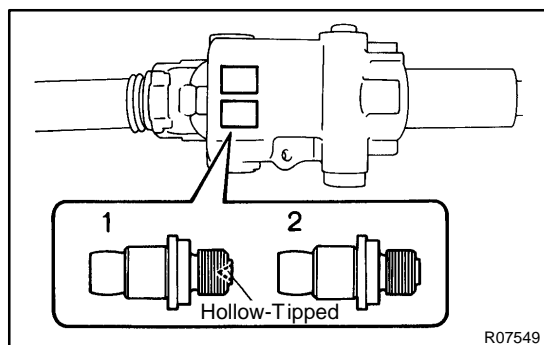

4. SELECT 2 TILT NO.2 BOLTS

Select the bolt with the hollow-tipped thread end when the column upper tube mark is 1, and the bolt with the plain thread end when the mark is 2.

NOTICE:

Select the bolt type to match each number marked in the squares on the upper tube.

5. INSTALL COLUMN UPPER TUBE WITH MAIN SHAFT ASSEMBLY

- (a) Install the upper tube with the shaft assembly into the lower tube.

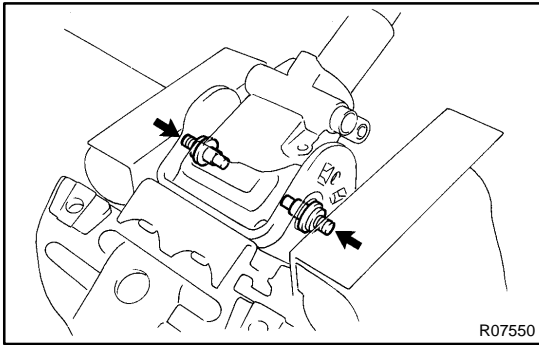

(b) Using a vise, press in the 2 tilt No.2 bolts.

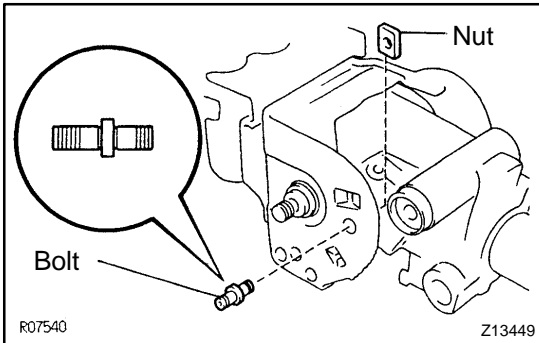

6. INSTALL TILT MEMORY BOLT AND SQUARE NUT

(a) Apply sealant to 2 or 3 threads of the bolt.

Sealant:

Part No. 08833-00080, THREE BOND 1344, LOCTITE 242 or equivalent.

(b) Using a hexagon wrench (4 mm), install the shorter side of the bolt to the nut.

Torque: 6.4 N·m (65 kgf·cm, 56 in.-lbf)

7. INSTALL TILT LEVER LOCK SHAFT, TILT LEVER ASSEMBLY, TILT SUB LEVER AND TILT LEVER

Temporarily tighten the tilt lever assembly set bolt.

8. INSTALL 2 TILT PAWLS

(a) Temporarily install the bolt, washer and nut.

HINT:

Install the pin of the pawl into the long hole of the tilt lever / tilt sub lever.

(b) Torque the tilt lever assembly set bolt.

Torque: 4.7 N·m (48 kgf·cm, 42 in.-lbf)

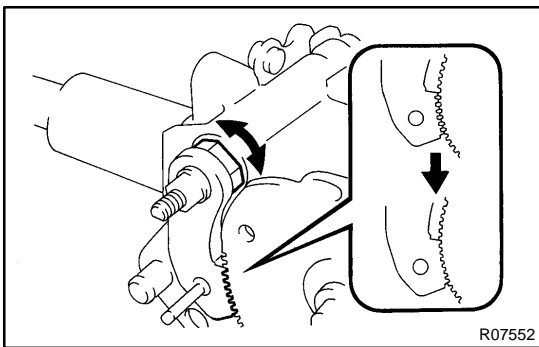

9. ENGAGE AND ADJUST 2 TILT PAWLS

(a) Engage the tilt sub lever side pawl to the center of the ratchet.

(b) Using a spanner (17 mm), while turning the collar, completely engage the tilt lever side pawl to the ratchet.

NOTICE:

- ◆ Do not turn the collar after the tilt lever side pawl is engaged.
- ◆ Keep the bolt and nut temporarily tightened.

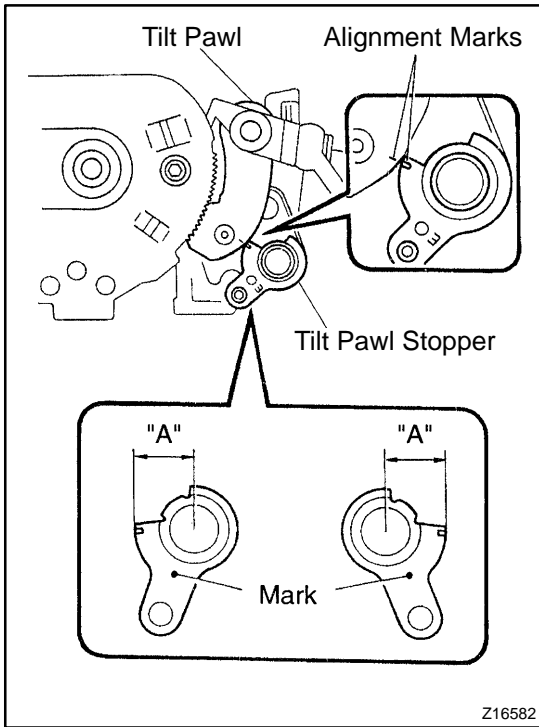

10. SELECT 2 TILT PAWL STOPPERS

- (a) With the tilt pawl and ratchet engaged, install the stopper.
- (b) Check that the alignment marks on the stopper and pawl align when the stopper is lightly rotated to the pawl side.
- (c) If the alignment marks do not align, select pawl stoppers according to the following table.

Tilt sub lever side	Tilt lever side	Dimension "A" mm (in.)
1	A	12.68 - 12.74 (0.4992 - 0.5016)
2	B	12.61 - 12.67 (0.4965 - 0.4988)
3	C	12.54 - 12.60 (0.4937 - 0.4961)
4	D	12.47 - 12.53 (0.4909 - 0.4933)
5	E	12.40 - 12.46 (0.4882 - 0.4906)
6	F	12.33 - 12.39 (0.4854 - 0.4878)
7	G	12.26 - 12.32 (0.4827 - 0.4850)

- (d) After selecting the stopper, check that on both sides the pawl and ratchet are fully engaged.

11. INSTALL 2 TILT PAWL STOPPERS

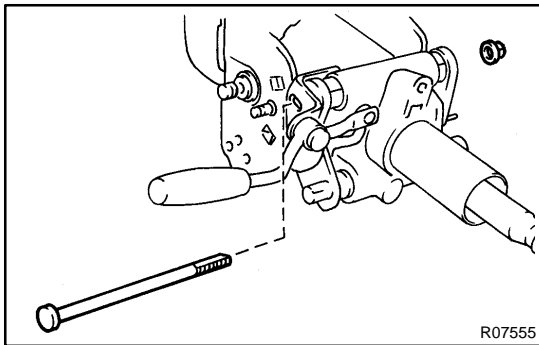

**12. Tilt Sub Lever Side:
INSTALL TILT LEVER RETAINER**

- (a) Remove the bolt and nut.

NOTICE:

Take care not to turn the collar of the tilt sub lever side pawl.

- (b) Install the collar to the tilt memory bolt.
- (c) Install the retainer.
- (d) Install the bolt and washer, and torque the nut.

HINT:

Install the bolt so that the groove in the bolt shaft faces upward.

Torque: 5.9 N-m (60 kgf-cm, 52 in.-lbf)

- (e) Torque the nut of the tilt No.2 bolt side.
Torque: 15 N-m (150 kgf-cm, 11 ft-lbf)
- (f) Torque the nut of the memory bolt side.
Torque: 5.9 N-m (60 kgf-cm, 52 in.-lbf)
- (g) Install the spacer and a new E-ring.

**13. Tilt Lever Side:
INSTALL TILT LEVER RETAINER**

- (a) Torque the nut.
Torque: 15 N-m (150 kgf-cm, 11 ft-lbf)

(b) Install a new E-ring.

14. INSTALL TURN SIGNAL BRACKET

(a) Apply sealant to 2 or 3 threads of the 2 bolts.

Sealant:

Part No. 08833-00080, THREE BOND 1344, LOCTITE 242 or equivalent.

(b) Torque the 2 bolts.

Torque: 8.8 N·m (90 kgf·cm, 78 in.-lbf)

15. INSTALL STEERING DAMPER

Torque the 2 bolts.

16. INSTALL 3 TENSION SPRINGS

17. INSTALL COMPRESSION SPRING

(a) Install the 2 bushings to the spring.

(b) Apply sealant to 2 or 3 threads of the torx screw.

Sealant:

Part No. 08833-00080, THREE BOND 1344, LOCTITE 242 or equivalent.

(c) Using a torx socket wrench, torque the screw.

Torque: 6.4 N·m (65 kgf·cm, 56 in.-lbf)

18. INSTALL COLUMN PROTECTOR AND WIRING HARNESS CLAMP

Tighten the 2 screws.

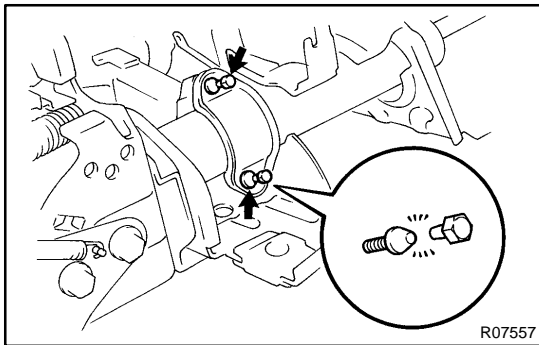

19. INSTALL COLUMN UPPER BRACKET AND COLUMN UPPER CLAMP

Tighten 2 new tapered-head bolts until the bolt head breaks off.

20. INSTALL COLUMN LOWER COVER

Tighten the clamp.

21. INSTALL SHAFT THRUST STOPPER AND SLIDING YOKE

(a) Align the matchmarks on the yoke and main shaft.

(b) Torque the bolt.

Torque: 35 N·m (360 kgf·cm, 26 ft-lbf)

22. INSTALL INTERMEDIATE SHAFT

Temporarily tighten the bolt.

23. INSTALL IGNITION KEY CYLINDER ILLUMINATION

24. CHECK TILT OPERATION

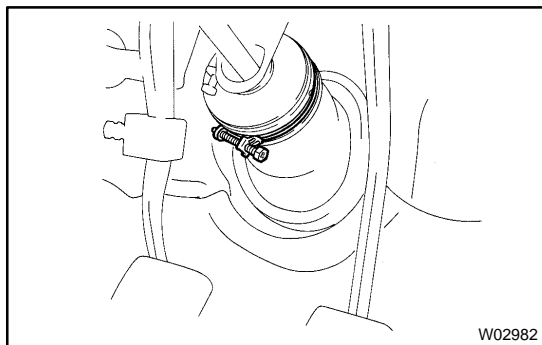

INSTALLATION

1. INSTALL STEERING COLUMN ASSEMBLY

- (a) Torque the 4 column assembly set nuts.
Torque: 25 N·m (260 kgf·cm, 19 ft·lbf)
- (b) Connect the connectors.
- (c) Install the brake pedal return spring.
- (d) Tighten the hole cover clamp.

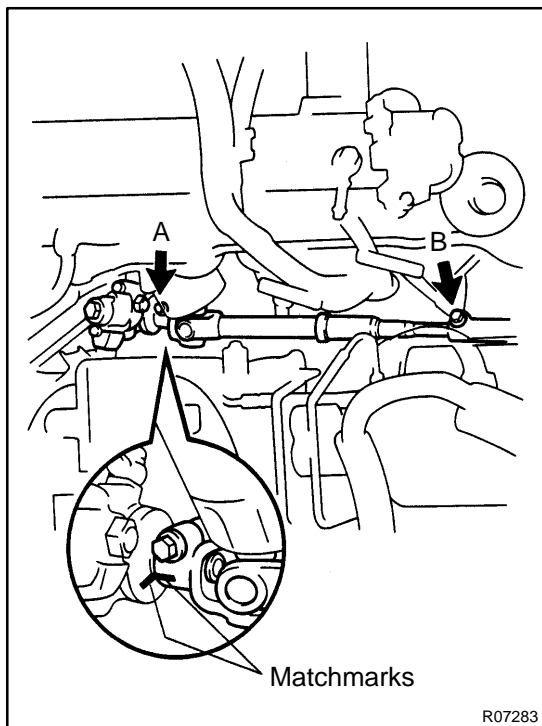

2. CONNECT INTERMEDIATE SHAFT

- (a) Align the matchmarks on the intermediate shaft and control valve shaft.
- (b) Torque the bolt A.
Torque: 35 N·m (360 kgf·cm, 26 ft·lbf)
- (c) Torque the bolt B.
Torque: 35 N·m (360 kgf·cm, 26 ft·lbf)

3. INSTALL SPIRAL CABLE

(See page [BE-16](#))

4. INSTALL COMBINATION SWITCH WITH SPIRAL CABLE

- (a) Tighten the 4 screws.
- (b) Connect the connectors and airbag connector.

5. INSTALL THESE PARTS:

(See page [BO-59](#))

- (a) Heater to Register No.2 duct
- (b) Finish lower LH panel
- (c) Finish panel
- (d) Cluster finish center panel
- (e) Cluster finish panel LH
- (f) Cluster finish panel RH
- (g) Cluster finish panel
- (h) Console upper panel

6. INSTALL COLUMN UPPER AND LOWER COVERS

Tighten the 5 screws.

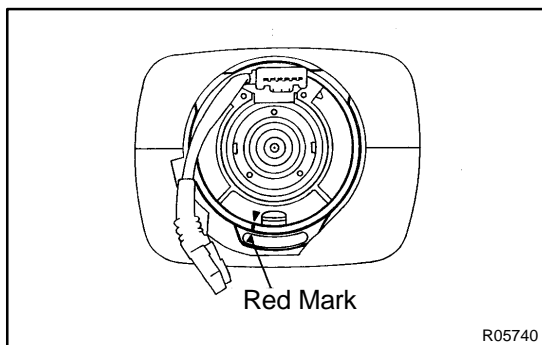

7. CENTER SPIRAL CABLE

- (a) Check that the front wheels are facing straight ahead.
- (b) Turn the spiral cable counterclockwise by hand until it becomes harder to turn the cable.
- (c) Rotate the spiral cable clockwise about 3 turns to align the marks.

HINT:

The spiral cable will rotate about 3 turns to either left or right of the center.

8. INSTALL STEERING WHEEL

- (a) Align the matchmarks on the wheel and main shaft.
- (b) Torque the wheel set nut.

Torque: 35 N·m (360 kgf·cm, 26 ft·lbf)

- (c) Connect the connector.

9. INSTALL STEERING WHEEL PAD**NOTICE:**

Make sure the pad is installed to the specified torque. If the pad has been dropped, or there are cracks, dents or other defects in the case or connector, replace the pad with a new one. When installing the pad, take care that the wiring does not interfere with other parts and is not pinched between other parts.

- (a) Connect the airbag connector.

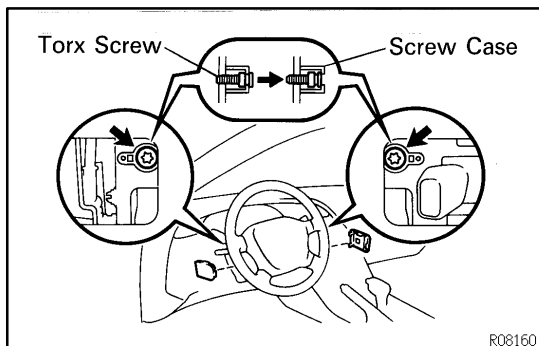

- (b) Install the pad after confirming that the circumference of the torx screw groove is caught on the screw case.
- (c) Using a torx socket wrench, torque the 2 screws.

Torque: 7.1 N·m (72 kgf·cm, 62 in·lbf)

10. CHECK STEERING WHEEL CENTER POINT

POWER STEERING VANE PUMP COMPONENTS

SR143-01

2JZ-GE:

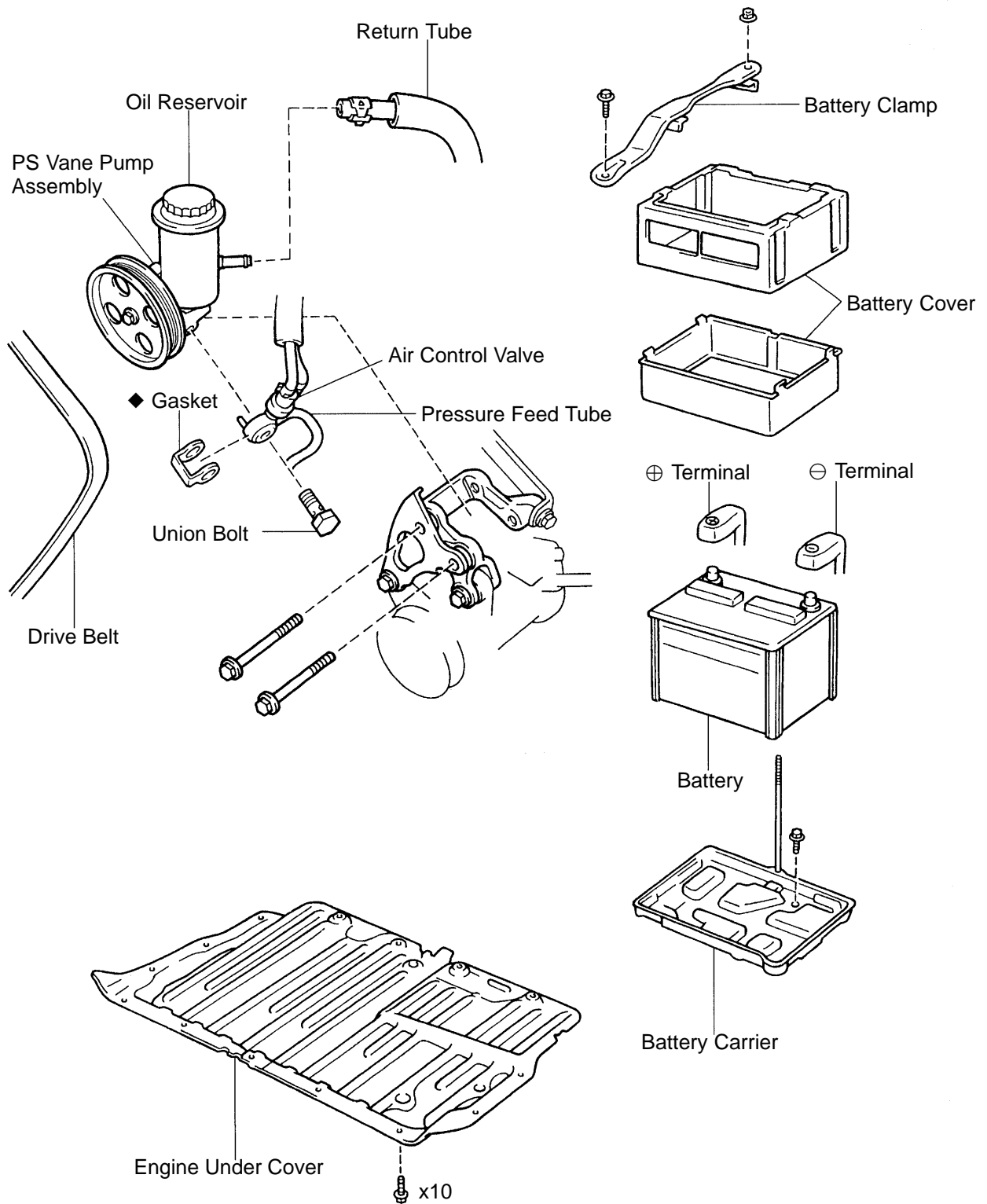

◆ Non-reusable part

Z18268

2JZ-GTE:

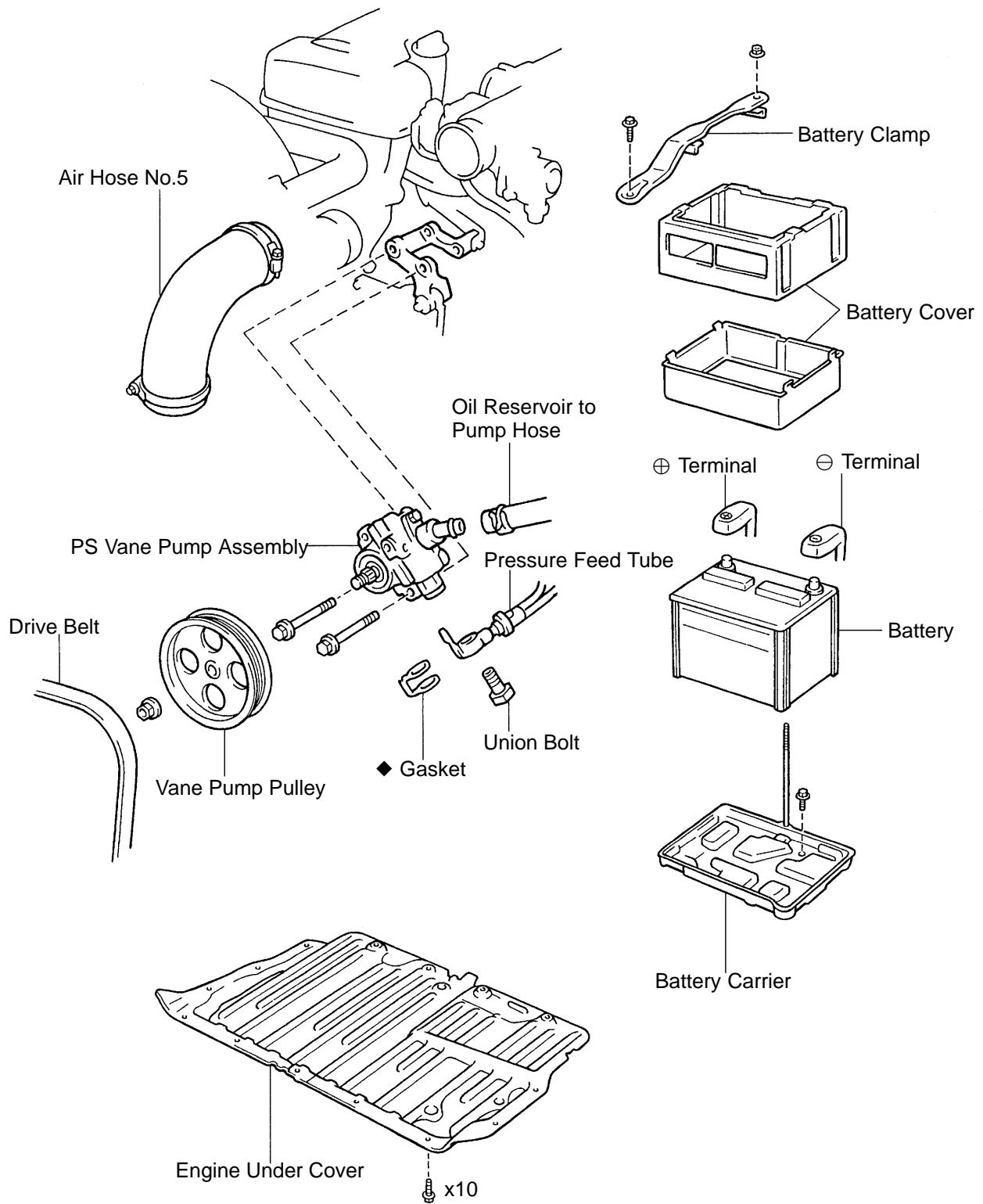

◆ Non-reusable part

Z18269

2JZ-GE and 2JZ-GTE:

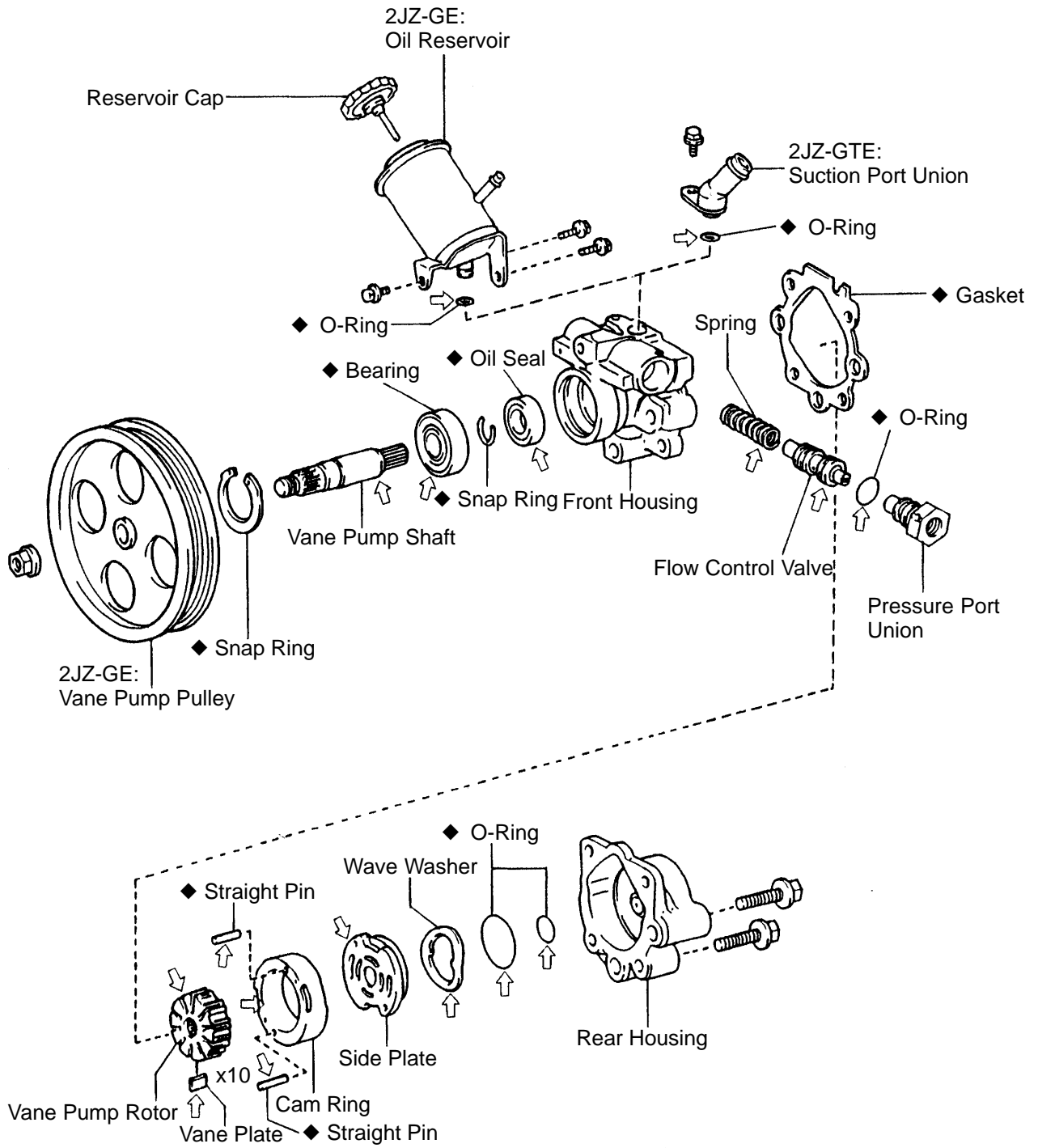

◆ Non-reusable part
 ⇐ Power steering fluid

Z19281

REMOVAL

1. REMOVE ENGINE UNDER COVER

Remove the 10 screws.

2. REMOVE BATTERY

- (a) Disconnect the 2 terminals.
- (b) Remove the bolt, nut and battery clamp.
- (c) Remove the battery cover.
- (d) Remove the battery and battery carrier.

3. 2JZ-GTE:

REMOVE AIR HOSE No.5

4. REMOVE DRIVE BELT

Loosen the drive belt tension by turning the drive belt tensioner clockwise, and remove the drive belt.

5. 2JZ-GTE:

DISCONNECT OIL RESERVOIR TO PUMP HOSE

Remove the clip and disconnect the hose.

NOTICE:

Take care not to spill fluid on the A/C compressor rotor.

6. 2JZ-GE:

DISCONNECT RETURN TUBE

NOTICE:

Take care not to spill fluid on the A/C compressor rotor.

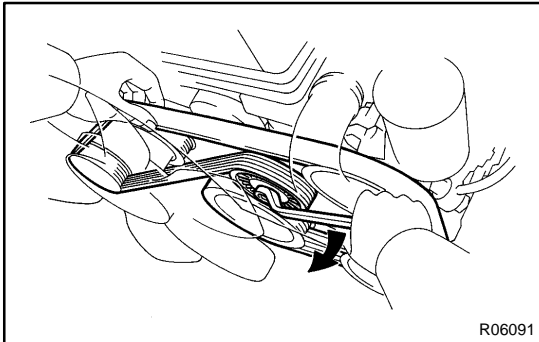

R06091

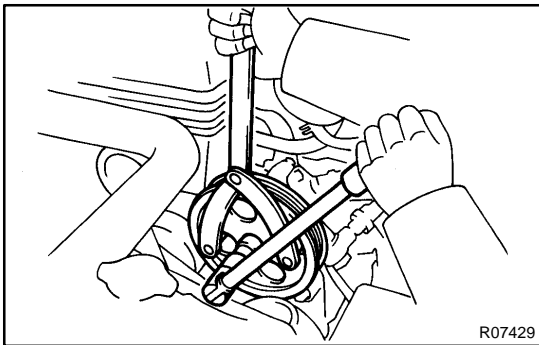

R07429

7. 2JZ-GTE:

REMOVE VANE PUMP PULLEY

Using SST to stop the pulley rotating, remove the nut.

SST 09960-10010 (09962-01000, 09963-01000)

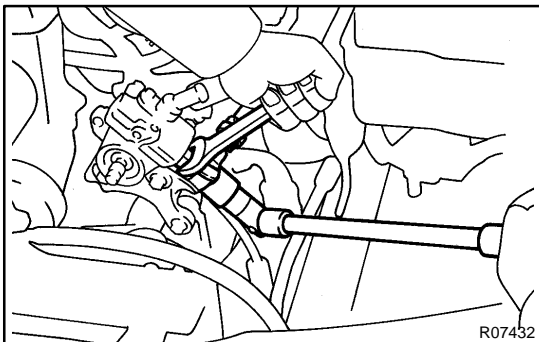

R07432

8. REMOVE PRESSURE FEED TUBE

Using a spanner (24 mm) to hold the pressure port union, remove the union bolt and gasket.

9. REMOVE PS VANE PUMP ASSEMBLY

Remove the 2 pump assembly set bolts.

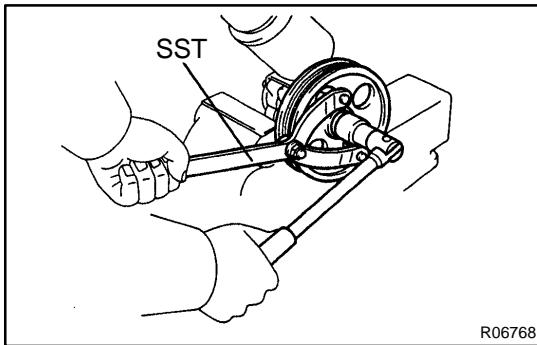

DISASSEMBLY

NOTICE:

When using a vise, do not overtighten it.

1. 2JZ-GE:

REMOVE VANE PUMP PULLEY

Using SST to stop the pulley rotating, remove the pulley set nut.
SST 09960-10010 (09962-01000, 09963-01000)

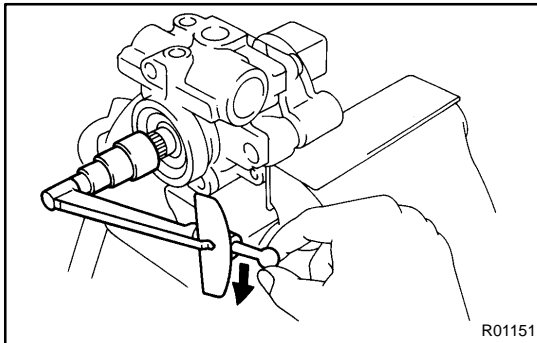

2. MEASURE PS VANE PUMP ROTATING TORQUE

(a) Check that the pump rotates smoothly without abnormal noise.

(b) Temporarily install the pulley set nut, and using a torque wrench, check the pump rotating torque.

Rotating torque:

0.2 N·m (2.5 kgf·cm, 2.2 in.-lbf) or less

3. 2JZ-GE:

REMOVE OIL RESERVOIR

(a) Remove the 3 bolts.

(b) Remove the O-ring from the reservoir.

4. 2JZ-GTE:

REMOVE SUCTION PORT UNION

(a) Remove the bolt.

(b) Remove the O-ring from the union.

5. REMOVE PRESSURE PORT UNION, FLOW CONTROL VALVE AND SPRING

Remove the O-ring from the union.

6. REMOVE REAR HOUSING

Remove the 2 bolts.

7. REMOVE CAM RING, VANE PUMP ROTOR AND 10 VANE PLATES

NOTICE:

Be careful not to drop the vane plates.

8. REMOVE 2 STRAIGHT PINS

9. REMOVE GASKET

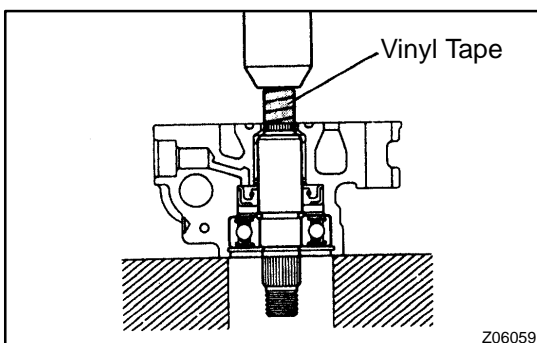

10. REMOVE VANE PUMP SHAFT WITH BEARING

(a) Using snap ring pliers, remove the snap ring from the front housing.

(b) Wind vinyl tape on the serrated part of the shaft.

(c) Using a press, press out the shaft with the bearing.

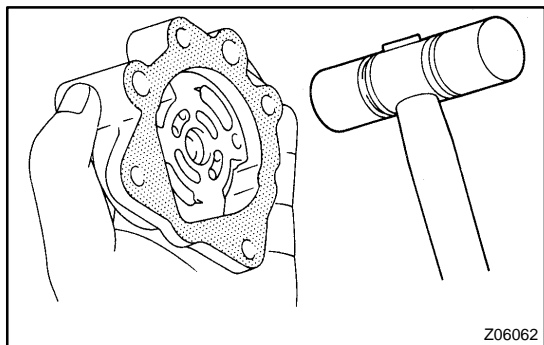
**11. REMOVE SIDE PLATE AND WAVE WASHER**

- (a) Using a plastic hammer, tap the rear housing on the shaded area until the plate and washer come off.
- (b) Remove the 2 O-rings from the rear housing.

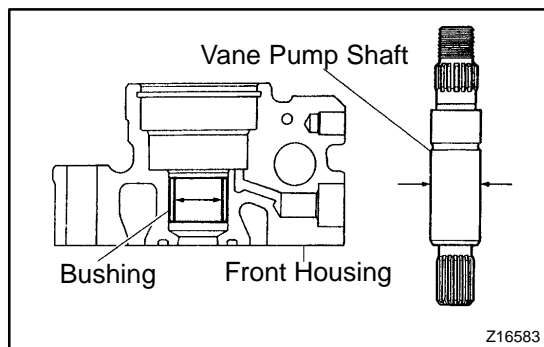

INSPECTION

NOTICE:

When using a vise, do not overtighten it.

1. MEASURE OIL CLEARANCE BETWEEN VANE PUMP SHAFT AND BUSHING

Using a micrometer and a caliper gauge, measure the oil clearance.

Standard clearance:

0.03 - 0.05 mm (0.0012 - 0.0020 in.)

Maximum clearance:

0.07 mm (0.0028 in.)

If it is more than maximum, replace the front housing and vane pump shaft.

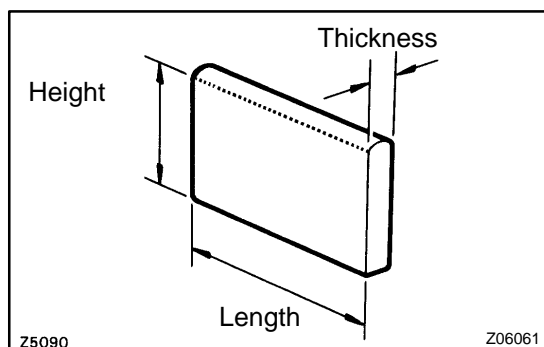

2. INSPECT VANE PUMP ROTOR AND VANE PLATES

(a) Using a micrometer, measure the height, thickness and length of the 10 vane plates.

Minimum height: 8.6 mm (0.339 in.)

Minimum thickness: 1.40 mm (0.0551 in.)

Minimum length: 14.99 mm (0.5902 in.)

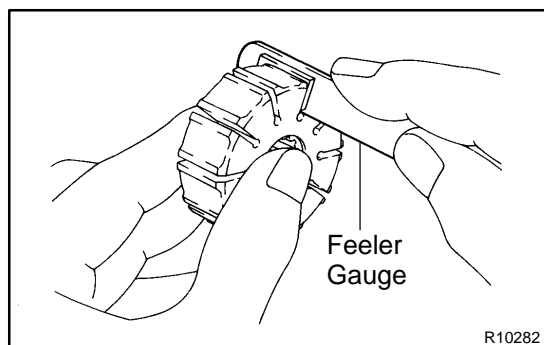

(b) Using a feeler gauge, measure the clearance between the rotor groove and plate.

Maximum clearance: 0.035 mm (0.0014 in.)

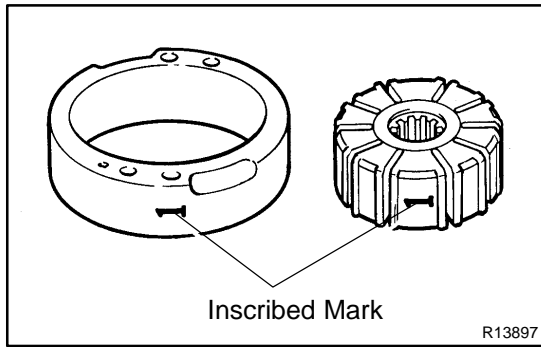

If it is more than the maximum, replace the plate and/or rotor with one having the same mark stamped on the cam ring.

**Inscribed mark:
1, 2, 3, 4 or None**

HINT:

There are 5 vane plate lengths with the following rotor and cam ring marks:

Rotor and cam ring mark	Vane plate part number	Vane plate length mm (in.)
None	44345-26010	14.999-15.001 (0.59051-0.59059)
1	44345-26020	14.997-14.999 (0.59043-0.59051)
2	44345-26030	14.995-14.997 (0.59035-0.59043)
3	44345-26040	14.993-14.995 (0.59027-0.59035)
4	44345-26050	14.991-14.993 (0.59020-0.59027)

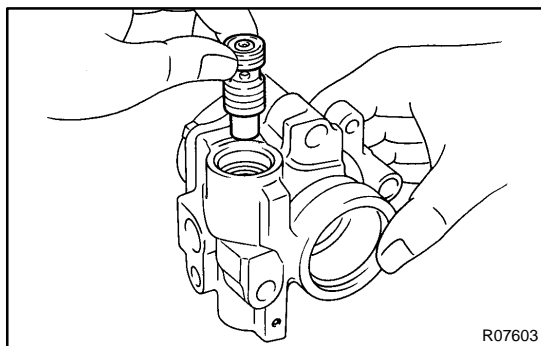

3. INSPECT FLOW CONTROL VALVE

(a) Coat the valve with power steering fluid and check that it falls smoothly into the valve hole by its own weight.

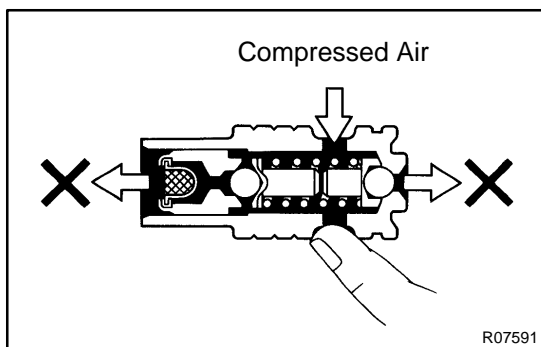

(b) Check the valve for leakage. Close one of the holes and apply 392 - 490 kPa (4 - 5 kgf/cm², 57 - 71 psi) of compressed air into the opposite side, and confirm that air does not come out from the end holes.

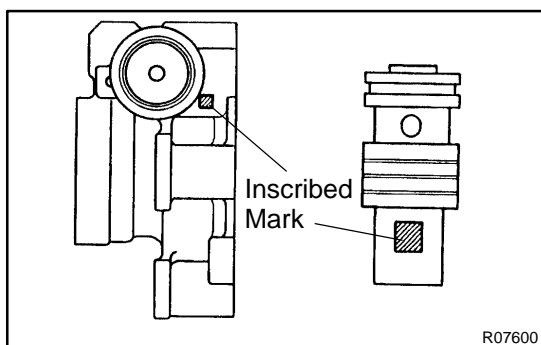

If necessary, replace the valve with one having the same letter as inscribed on the front housing.

**Inscribed mark:
A, B, C, D, E or F**

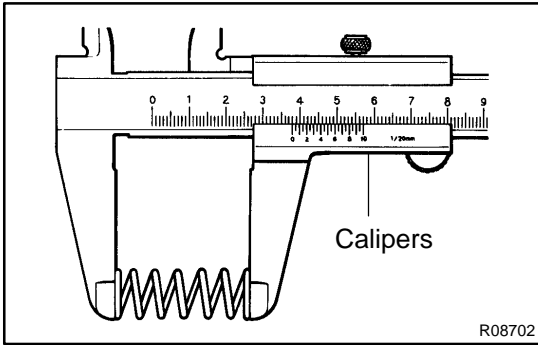

4. INSPECT SPRING

Using calipers, measure the free length of the spring.
Minimum free length: 33mm (1.30 in.)
 If it is not within the specification, replace the spring.

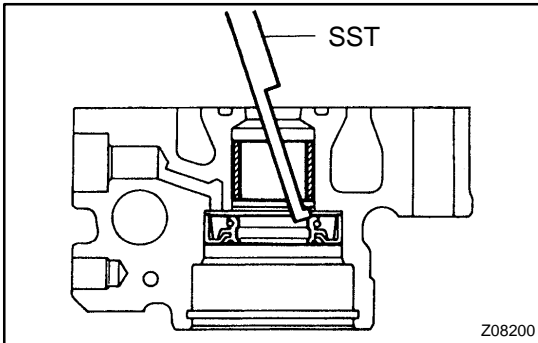

5. IF NECESSARY, REPLACE OIL SEAL

- (a) Using SST, tap out the oil seal.
 SST 09631-10030

NOTICE:

Be careful not to damage the bushing of the front housing.

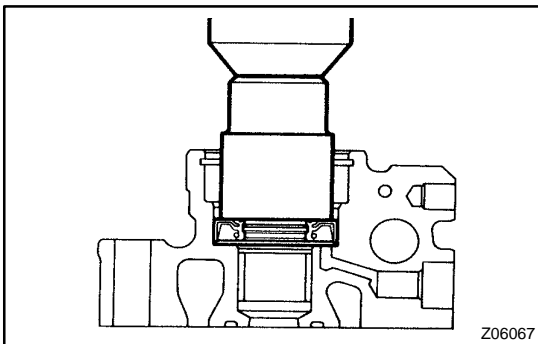

- (b) Coat a new oil seal lip with power steering fluid.
- (c) Using a socket wrench (24 mm), press in the oil seal.

NOTICE:

Make sure to install the oil seal facing the correct direction.

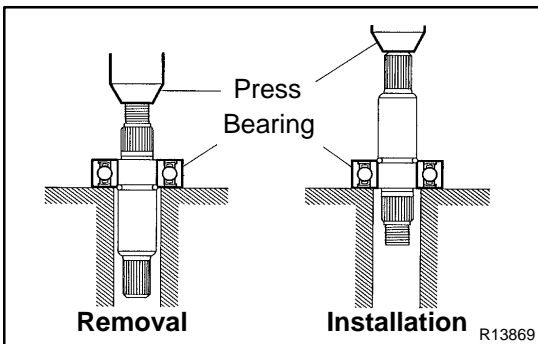

6. IF NECESSARY, REPLACE BEARING

- (a) Using a press, press out the bearing.
- (b) Using a snap ring expander, remove the snap ring from the vane pump shaft.

NOTICE:

Be careful not damage the vane pump shaft.

- (c) Using a snap ring expander, install a new snap ring.

NOTICE:

Be careful not damage the vane pump shaft.

- (d) Coat a new bearing with power steering fluid.
- (e) Using a press, press in the bearing.

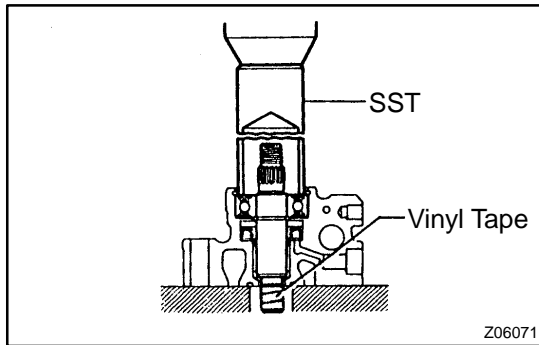

REASSEMBLY

NOTICE:

When using a vise, do not overtighten it.

1. **COAT WITH POWER STEERING FLUID**
(See page [SR-23](#))
2. **INSTALL VANE PUMP SHAFT WITH BEARING**
 - (a) Wind vinyl tape on the serrated part of the shaft.
 - (b) Using SST, press in the shaft with the bearing to the front housing.
SST 09608-04031

NOTICE:

Be careful not to damage the oil seal.

- (c) Using snap ring pliers, install a new snap ring to the front housing.
3. **INSTALL STRAIGHT PINS**
Using a plastic hammer, drive in 2 new straight pins to the front housing.

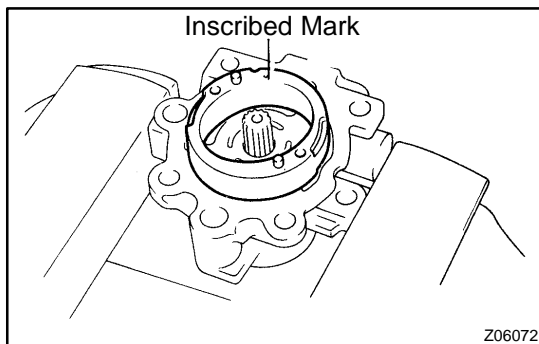

4. INSTALL CAM RING

Align the holes of the ring and straight pins, and install the ring with the inscribed mark facing outward.

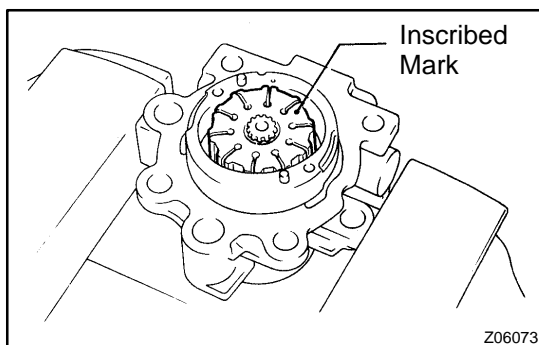

5. INSTALL VANE PUMP ROTOR

Install the rotor with the inscribed mark facing outward.

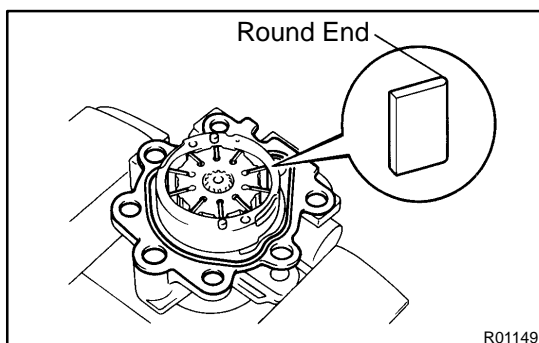

6. INSTALL 10 VANE PLATES

Install the plate with the round end facing outward.

7. INSTALL GASKET

Install a new gasket to the front housing.

8. INSTALL SIDE PLATE

Align the holes of the plate and straight pins.

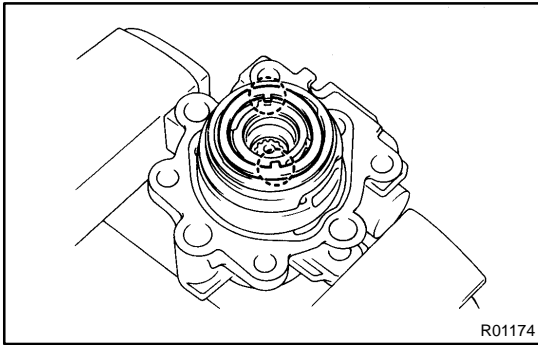
**9. INSTALL WAVE WASHER**

Install the washer so that its protrusions fit into the slots in the side plate.

10. INSTALL REAR HOUSING

(a) Coat 2 new O-rings with power steering fluid and install them to the housing.

(b) Torque the 2 bolts.

Torque: 17 N·m (170 kgf·cm, 12 ft·lbf)

11. INSTALL SPRING, FLOW CONTROL VALVE AND PRESSURE PORT UNION

(a) Coat a new O-ring with power steering fluid and install it to the union.

(b) Torque the union.

Torque: 83 N·m (850 kgf·cm, 61 ft·lbf)

**12. 2JZ-GTE:
INSTALL SUCTION PORT UNION**

(a) Coat a new O-ring with power steering fluid and install it to the union.

(b) Torque the bolt.

Torque: 13 N·m (130 kgf·cm, 9 ft·lbf)

**13. 2JZ-GE:
INSTALL OIL RESERVOIR**

(a) Coat a new O-ring with power steering fluid and install it to the reservoir.

(b) Torque the 3 bolts.

Torque:

Front side bolt: 13 N·m (130 kgf·cm, 9 ft·lbf)

Rear side bolts: 17 N·m (170 kgf·cm, 12 ft·lbf)

**14. MEASURE PS VANE PUMP ROTATING TORQUE
(See page [SR-27](#))****15. 2JZ-GE:
INSTALL VANE PUMP PULLEY**

Using SST to stop the pulley rotating, torque the nut.

SST 09960-10010 (09962-01000, 09963-01000)

Torque: 43 N·m (440 kgf·cm, 32 ft·lbf)

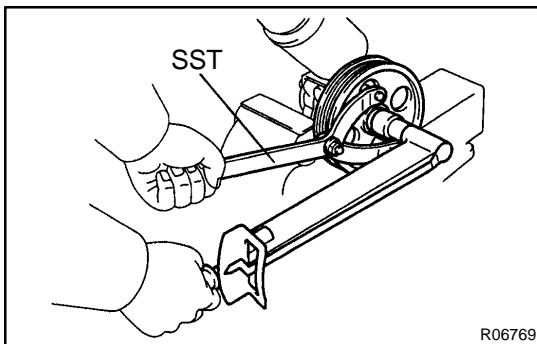

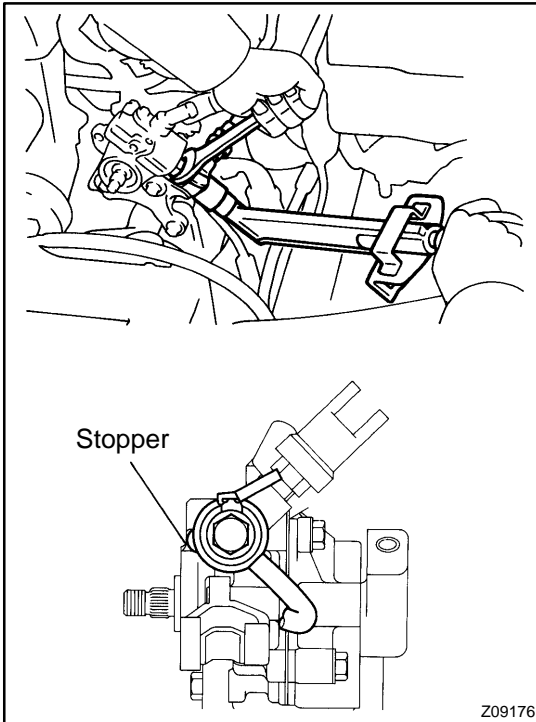

INSTALLATION

1. INSTALL PS VANE PUMP ASSEMBLY

Torque the 2 bolts.

Torque:

RH side bolt: 39 N-m (400 kgf-cm, 29 ft-lbf)

LH side bolt: 58 N-m (590 kgf-cm, 42 ft-lbf)

2. CONNECT PRESSURE FEED TUBE

Using a spanner (24 mm) to hold the pressure port union, torque the union bolt with a new gasket.

HINT:

Make sure that the stopper of the tube is touching the PS vane pump assembly as shown, before torquing the union bolt.

Torque: 49 N-m (500 kgf-cm, 36 ft-lbf)

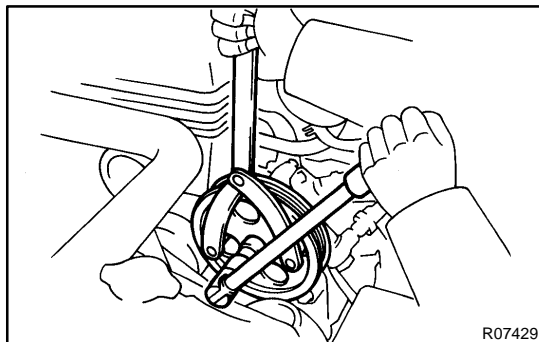

3. 2JZ-GTE:

INSTALL VANE PUMP PULLEY

Using SST to stop the pulley rotating, torque the nut.

SST 09960-10010 (09962-01000, 09663-01000)

Torque: 43 N-m (440 kgf-cm, 32 ft-lbf)

4. 2JZ-GE:

CONNECT RETURN TUBE

5. 2JZ-GTE:

CONNECT OIL RESERVOIR TO PUMP HOSE

Connect the hose and install the clip.

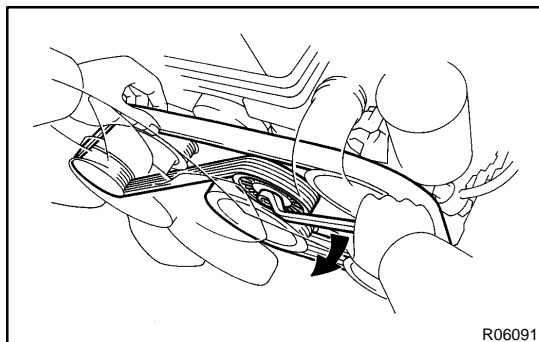

6. INSTALL DRIVE BELT

Loosen the drive belt tension by turning the drive belt tensioner clockwise, and install the drive belt.

7. 2JZ-GTE:

INSTALL AIR HOSE No.5

8. INSTALL BATTERY

(a) Install the battery carrier and battery.

(b) Install the battery cover.

(c) Install the battery clamp with bolt and nut.

(d) Connect the 2 terminals.

9. INSTALL ENGINE UNDER COVER

Install the 10 screws.

10. BLEED POWER STEERING SYSTEM

(See page [SR-3](#))

POWER STEERING GEAR COMPONENTS

SR149-01

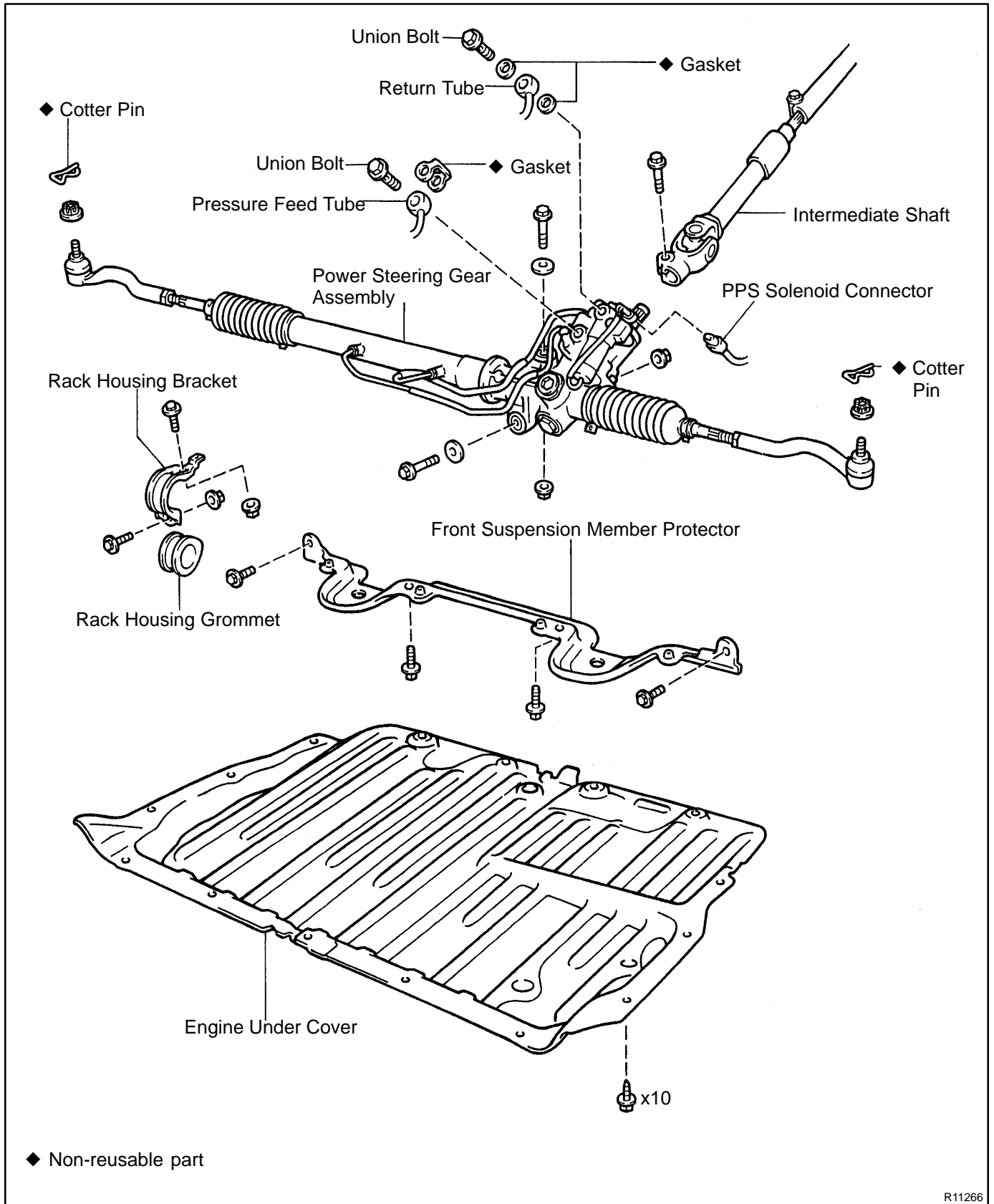

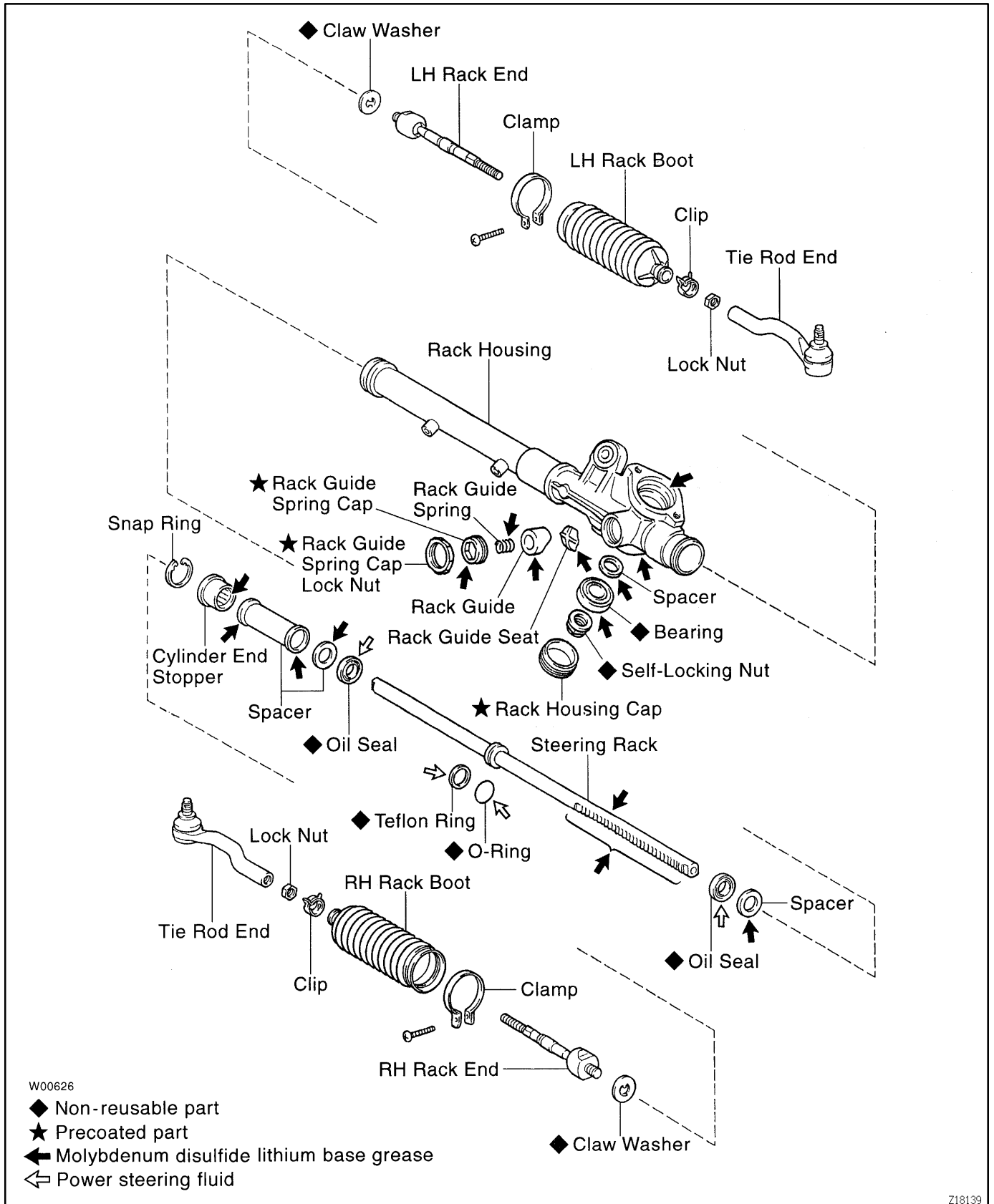

Z18139

STEERING - POWER STEERING GEAR

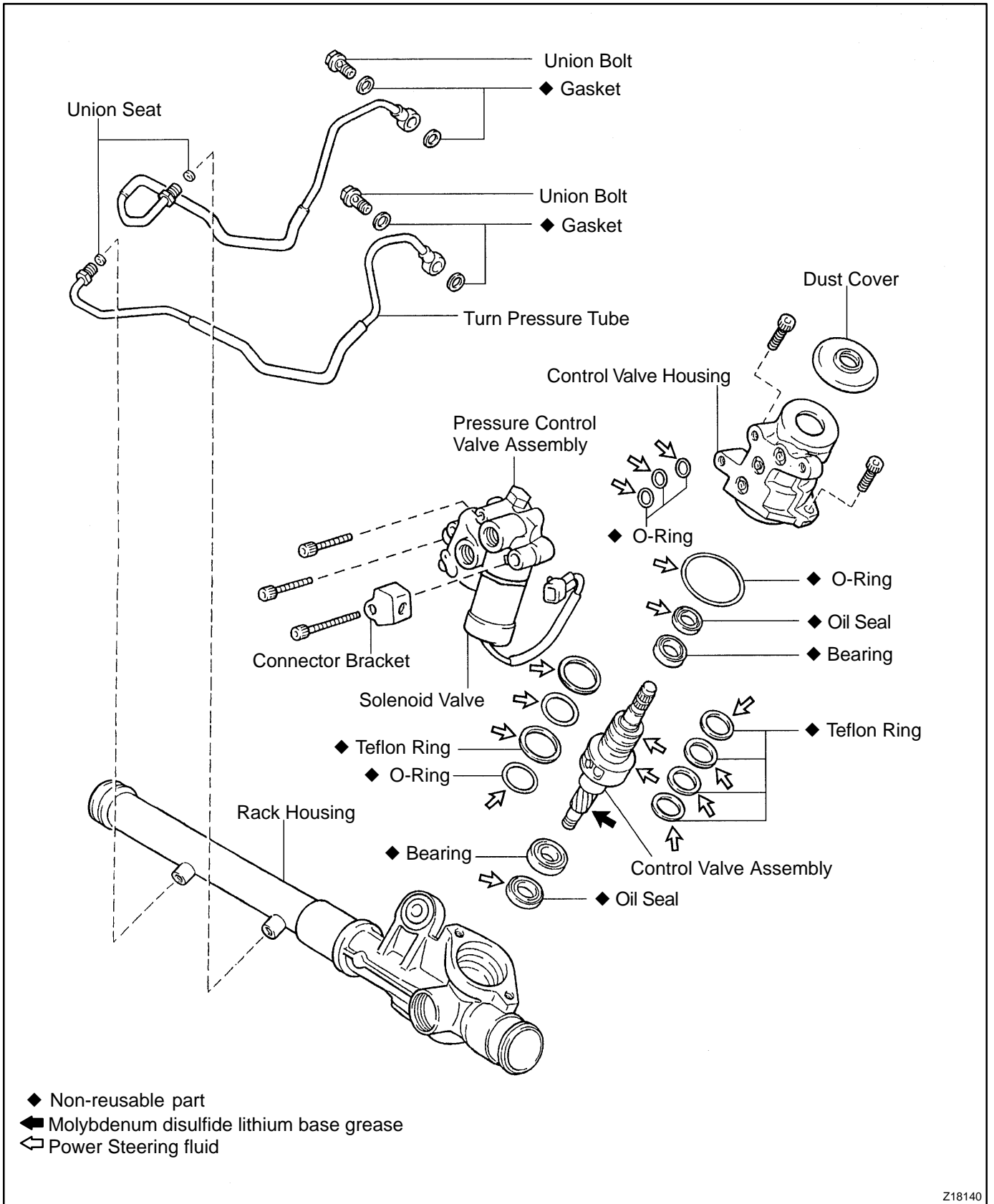

REMOVAL

1. PLACE FRONT WHEELS FACING STRAIGHT AHEAD
2. REMOVE STEERING WHEEL PAD
(See page [SR-1 1](#))
3. REMOVE STEERING WHEEL
(See page [SR-1 1](#))

4. REMOVE ENGINE UNDER COVER

Remove the 10 bolts.

5. REMOVE FR SUSPENSION MEMBER PROTECTOR

Remove the 4 bolts.

6. DISCONNECT INTERMEDIATE SHAFT
(See page [SR-1 1](#))

7. DISCONNECT RH AND LH TIE ROD ENDS
(See page [SA-12](#))

8. DISCONNECT PRESSURE FEED TUBE

Remove the union bolt and gasket.

9. DISCONNECT RETURN TUBE

Remove the union bolt and 2 gaskets.

10. DISCONNECT PPS SOLENOID CONNECTOR

11. REMOVE RACK HOUSING BRACKET AND GROMMET

Remove the 2 bolts and nuts.

12. REMOVE PS GEAR ASSEMBLY

Remove the 2 bolts and nuts.

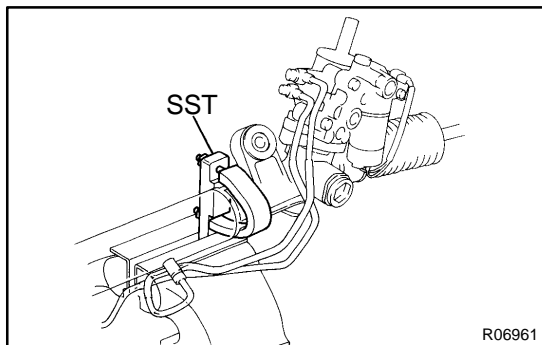

DISASSEMBLY

NOTICE:

When using a vise, do not overtighten it.

1. SECURE PS GEAR ASSEMBLY IN VISE

Using SST, secure the gear assembly in a vise.

SST 09612-00012

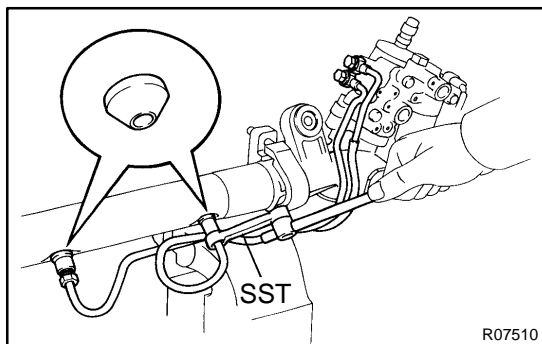

2. REMOVE 2 TURN PRESSURE TUBES

(a) Remove the union bolt and 2 gaskets.

(b) Using SST, remove the tube.

SST 09633-00020

(c) Remove the 2 union seats from the rack housing.

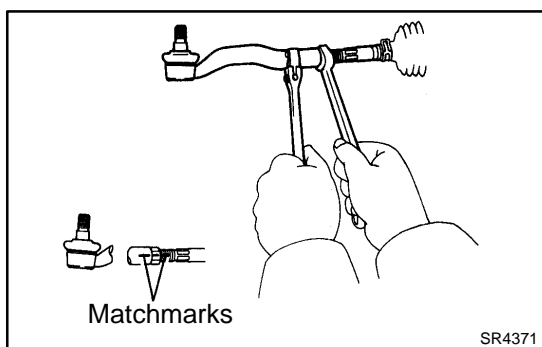

3. REMOVE RH AND LH TIE ROD ENDS AND LOCK NUTS

Place matchmarks on the tie rod end and rack end, and loosen the lock nut.

4. REMOVE RH AND LH CLIPS, RACK BOOTS AND CLAMPS

NOTICE:

- ◆ Be careful not to damage the boot.
- ◆ Mark the RH and LH boots.

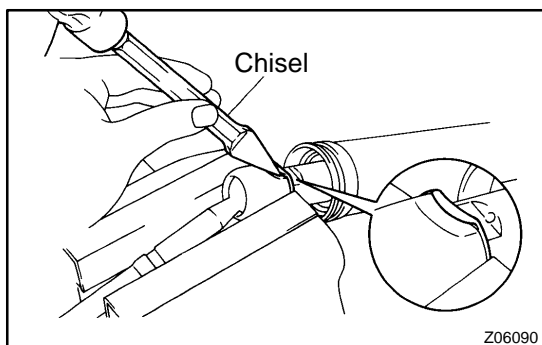

5. REMOVE RH AND LH RACK ENDS AND CLAW WASHERS

(a) Using a chisel and a hammer, unstake the washer.

NOTICE:

Avoid any impact to the steering rack.

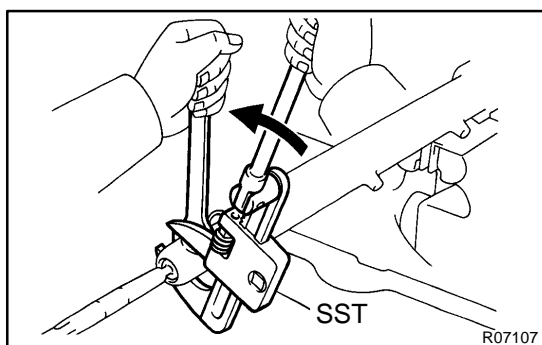

(b) Using a spanner (22 mm) to hold the steering rack and using SST, remove the rack end.

SST 09922-10010

NOTICE:

- ◆ Use SST 09922-10010 in the direction shown in the illustration.
- ◆ Mark the RH and LH rack ends.

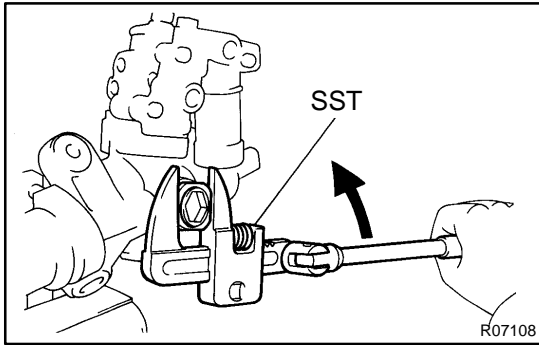
**6. REMOVE RACK GUIDE SPRING CAP LOCK NUT**

Using SST, remove the nut.

SST 09922-10010

NOTICE:

Use SST 09922-10010 in the direction shown in the illustration.

7. REMOVE RACK GUIDE SPRING CAP, RACK GUIDE SPRING, RACK GUIDE AND RACK GUIDE SEAT

Using a hexagon wrench (24 mm), remove the cap.

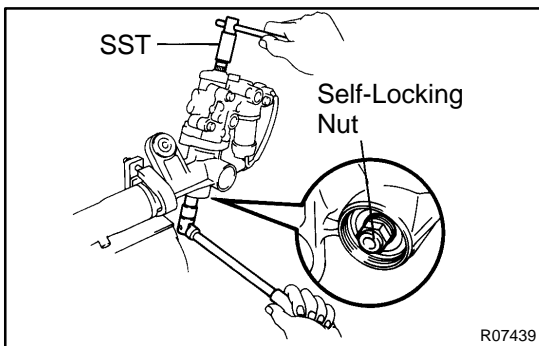
8. REMOVE RACK HOUSING CAP**9. REMOVE SELF-LOCKING NUT, BEARING AND SPACER**

Using SST to stop the control valve shaft rotating, remove the nut.

SST 09616-00010

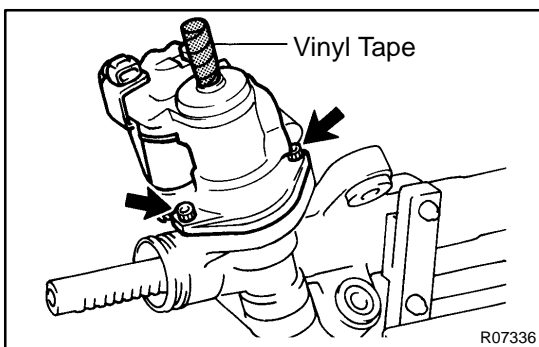
10. REMOVE DUST COVER**11. REMOVE CONTROL VALVE HOUSING WITH CONTROL VALVE ASSEMBLY**

(a) To prevent oil seal lip damage, wind vinyl tape on the serrated part of the control valve shaft.

(b) Using a hexagon wrench (6 mm), remove the 2 bolts.

(c) Remove the O-ring from the housing.

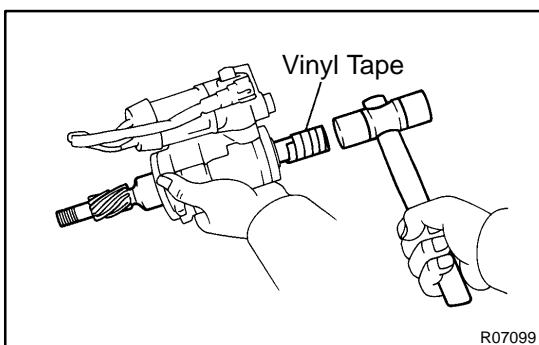
**12. REMOVE CONTROL VALVE ASSEMBLY**

Using a plastic hammer, tap out the control valve.

NOTICE:

Be careful not to damage the oil seal lip.

13. REMOVE CYLINDER END STOPPER AND 2 SPACERS

Using snap ring pliers, remove the snap ring from the rack housing.

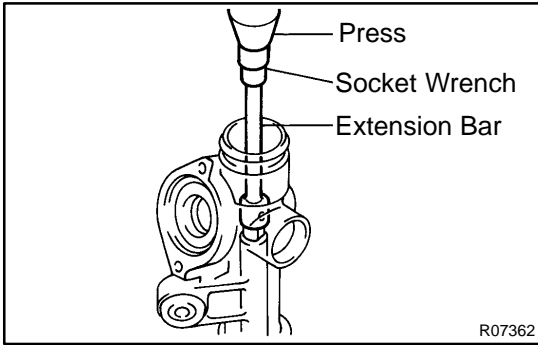

14. REMOVE STEERING RACK AND OIL SEAL

- (a) Using an extension bar or brass bar and a press, press out the rack with the oil seal.

NOTICE:

Take care not to drop the rack.

- (b) Remove the oil seal from the rack.

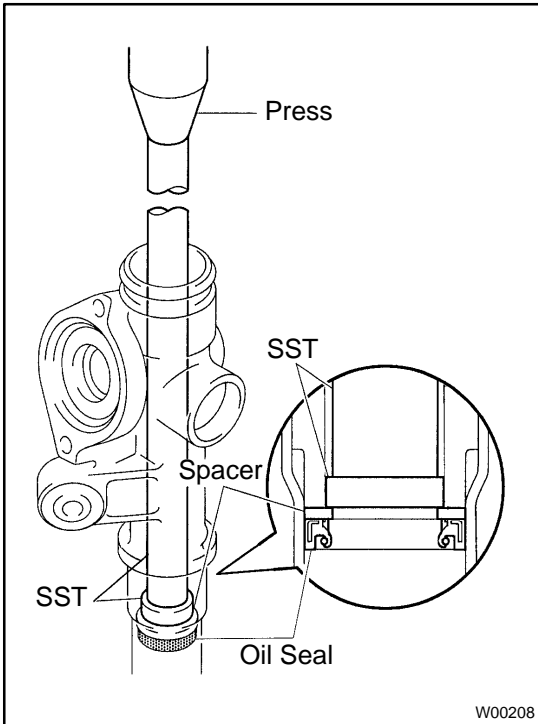

15. REMOVE OIL SEAL AND SPACER

Using SST, press out the oil seal and spacer.

- SST 09950-60010 (09951-00280),
- 09950-70010 (09951-07200)

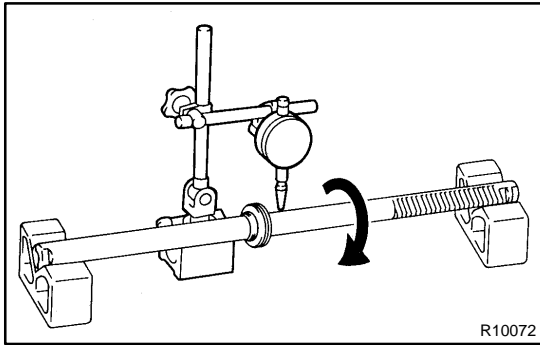

INSPECTION

NOTICE:

When using a vise, do not overtighten it.

1. INSPECT STEERING RACK

- (a) Using a dial indicator, check the rack for runout and for teeth wear or damage.

Maximum runout: 0.30mm (0.018 in.)

- (b) Check the back surface for wear or damage.

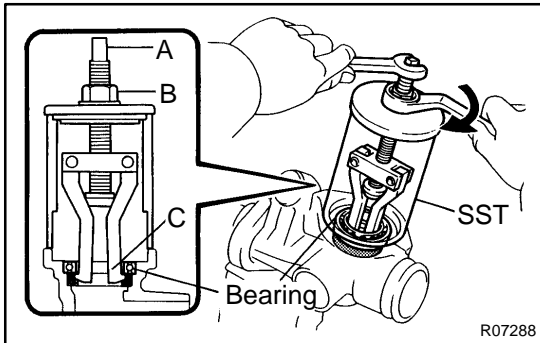

2. IF NECESSARY, REPLACE OIL SEAL AND BEARING

- (a) Set SST to the rack housing, as shown.

SST 09612-30012

- (b) Turn A clockwise and engage the tips of C on the bearing.

- (c) Using a spanner (8 mm), keep A fixed while turning nut B clockwise, and remove the bearing.

NOTICE:

Be careful not to damage the rack housing.

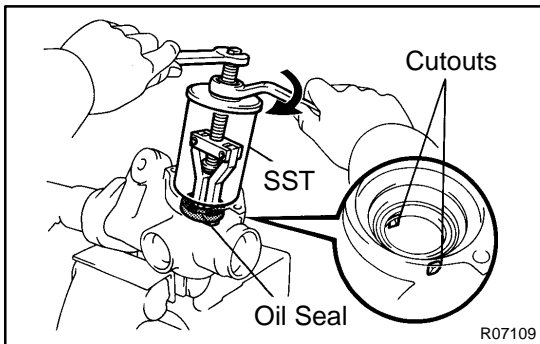

- (d) Using SST, remove the oil seal from the rack housing.

SST 09612-30012

NOTICE:

Be careful not to damage the rack housing.

HINT:

When using SST, apply the tips of SST to the cutouts in the rack housing.

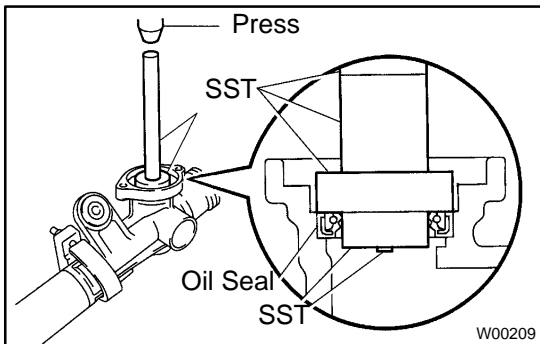

- (e) Coat a new oil seal lip with power steering fluid.

- (f) Using SST, press in the oil seal.

SST 09950-60010 (09951-00280, 09951-00390, 09952-06010), 09950-70010 (09951-07100)

NOTICE:

Make sure to install the oil seal facing the correct direction.

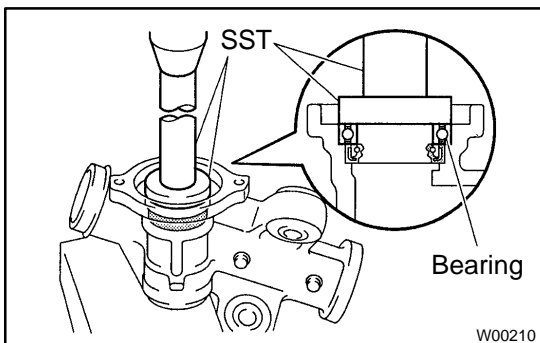

- (g) Using SST, press in the bearing.

SST 09950-60010 (09951-00460), 09950-70010 (09951-07100)

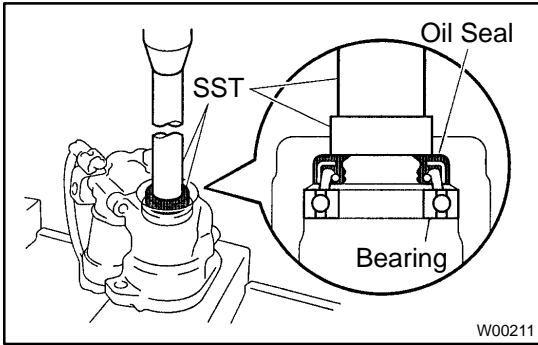

3. IF NECESSARY, REPLACE OIL SEAL AND BEARING

- (a) Using SST, press out the oil seal with the bearing from the control valve housing.

SST 09950-60010 (09951-00240),
09950-70010 (09951-07100)

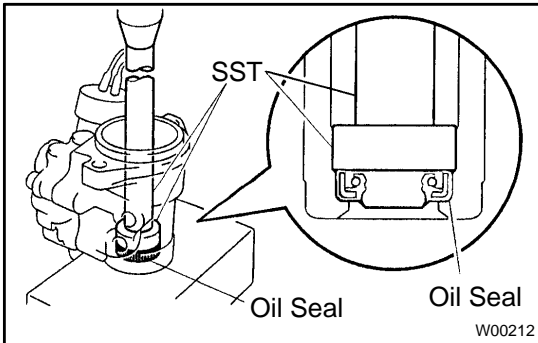

- (b) Coat a new oil seal lip with power steering fluid.

- (c) Using SST, press in the oil seal.

SST 09950-60010 (09951-00320),
09950-70010 (09951-07200)

NOTICE:

Make sure to install the oil seal facing the correct direction.

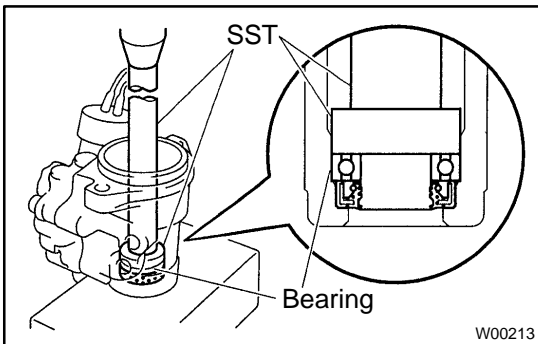

- (d) Using SST, press in the bearing.

SST 09950-60010 (09951-00340),
09950-70010 (09951-07200)

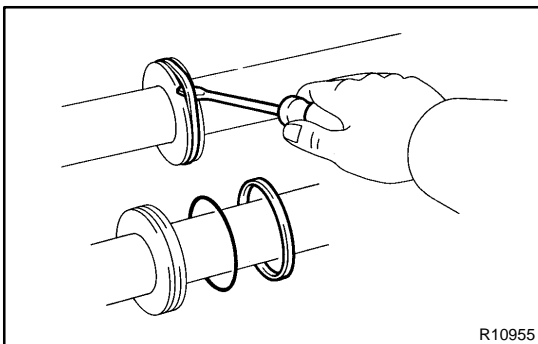

4. IF NECESSARY, REPLACE TEFLON RING AND O-RING

- (a) Using a screwdriver, remove the teflon ring and O-ring from the steering rack.

NOTICE:

Be careful not to damage the groove of the ring.

- (b) Coat a new O-ring with power steering fluid and install it.

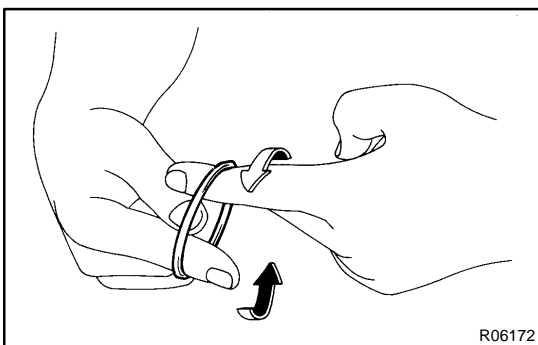

- (c) Expand a new teflon ring with your fingers.

NOTICE:

Be careful not to overexpand the ring.

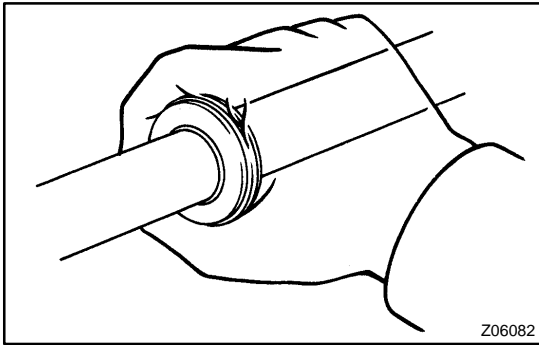

- (d) Coat the ring with power steering fluid.
- (e) Install the ring to the rack, and snug it down with your fingers.

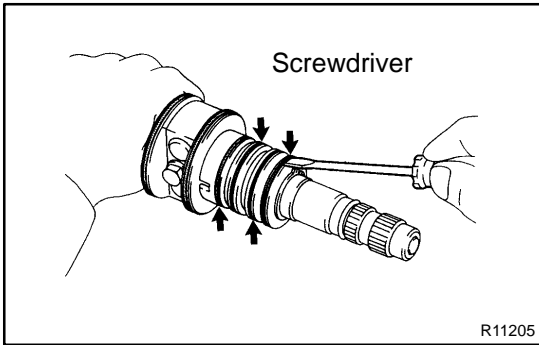

5. IF NECESSARY, REPLACE TEFLON RINGS

- (a) Using a screwdriver, remove the 4 rings from the control valve assembly.

NOTICE:

Be careful not to damage the grooves for the ring.

- (b) Expand 4 new rings with your fingers.

NOTICE:

Be careful not to overexpand the ring.

- (c) Coat the rings with power steering fluid.
- (d) Install the rings to the control valve assembly, and snug them down with your fingers.

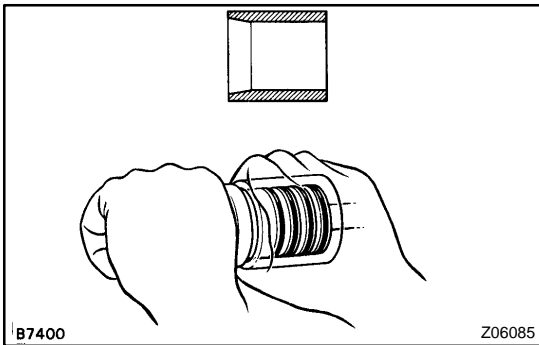

- (e) Carefully slide the tapered end of SST over the rings to seal them.

SST 09631-20081

NOTICE:

Be careful not to damage the rings.

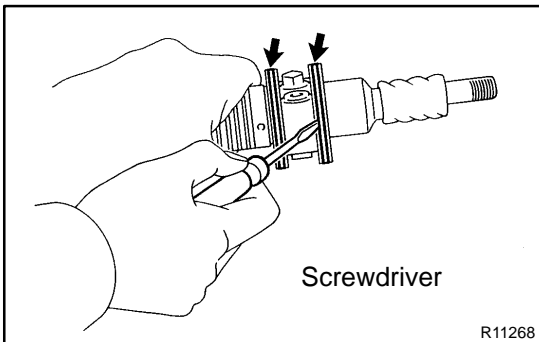

6. IF NECESSARY, REPLACE TEFLON RINGS AND O-RINGS

- (a) Using a screwdriver, remove the 2 teflon rings and O-rings from the control valve assembly.

NOTICE:

Be careful not to damage the grooves for the teflon ring.

- (b) Coat 2 new O-rings with power steering fluid, and install them.

- (c) Expand 2 new teflon rings with your fingers.

NOTICE:

Be careful not to overexpand the teflon rings.

- (d) Coat the rings with power steering fluid.
(e) Install the rings to the valve assembly, and snug them down with your fingers.
(f) Carefully slide the tapered end of SST over the teflon rings to seal them.

SST 09631-32020

NOTICE:

Be careful not to damage the teflon rings.

7. IF NECESSARY, REPLACE PRESSURE CONTROL VALVE ASSEMBLY

- (a) Using a hexagon wrench (6 mm), remove the 3 bolts and connector bracket.
(b) Remove the 3 O-rings from the control valve housing.
(c) Coat 3 new O-rings with power steering fluid, and install them.
(d) Using a hexagon wrench (6 mm), install a new pressure control valve and connector bracket with the 3 bolts.

Torque: 18 N·m (185 kgf-cm, 13 ft-lbf)

REASSEMBLY

NOTICE:

When using a vise, do not overtighten it.

1. **COAT WITH POWER STEERING FLUID OR MOLYBDENUM DISULFIDE LITHIUM BASE GREASE (See page SR-35)**

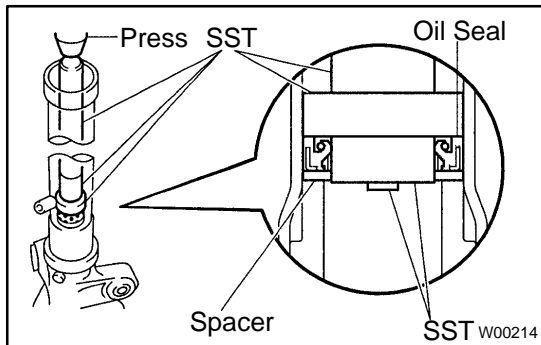

2. **INSTALL SPACER AND OIL SEAL**

- (a) Coat a new oil seal lip with power steering fluid.
- (b) Using SST, press in the oil seal.

SST 09950-60010 (09951-00240, 09951-00400, 09952-06010),
09950-70010 (09951-07360)

NOTICE:

- ◆ Make sure to install the oil seal facing the correct direction.
- ◆ Take care that the oil seal does not get reversed as you install it.

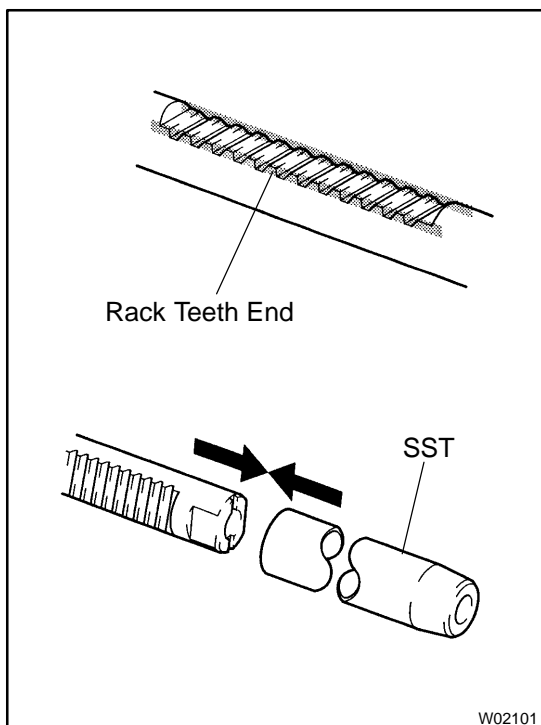

3. **INSTALL STEERING RACK**

- (a) Install SST to the rack.
SST 09631-20102

HINT:

If necessary, scrape the burrs off the rack teeth end and bur-nish.

- (b) Coat SST with power steering fluid.
- (c) Install the rack into the rack housing.

NOTICE:

- Be careful not to damage the oil seal lip.**
- (d) Remove the SST.

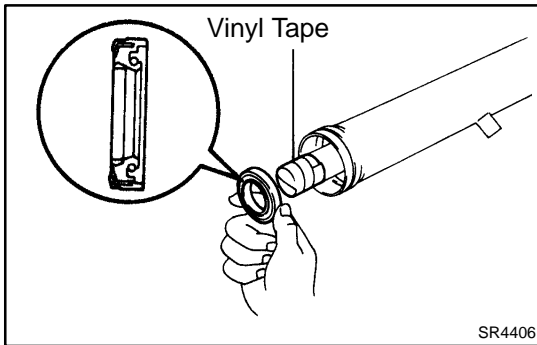

4. INSTALL OIL SEAL AND 2 SPACERS

- (a) To prevent oil seal lip damage, wind vinyl tape on the steering rack, and apply power steering fluid.
- (b) Coat a new oil seal lip with power steering fluid.
- (c) Install the oil seal by pushing it into the rack housing without tilting.

NOTICE:

- ◆ **Make sure to install the oil seal facing the correct direction.**
 - ◆ **Be careful not to damage the oil seal lip.**
- (d) Install the 2 spacers into the rack housing.

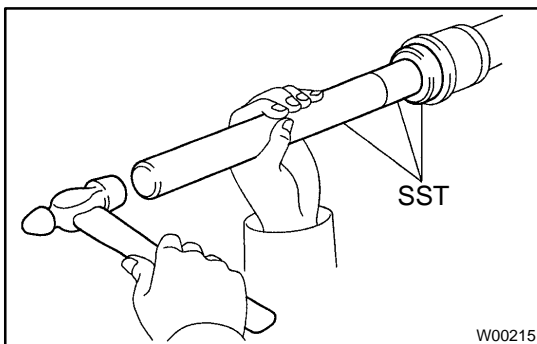

5. INSTALL CYLINDER END STOPPER

- (a) Using SST and a hammer, drive in the stopper.
SST 09950-60010 (09951-00270, 09951-00340, 09952-06010),
9950-70010 (09951-07200)
- (b) Using snap ring pliers, install the snap ring to the rack housing.

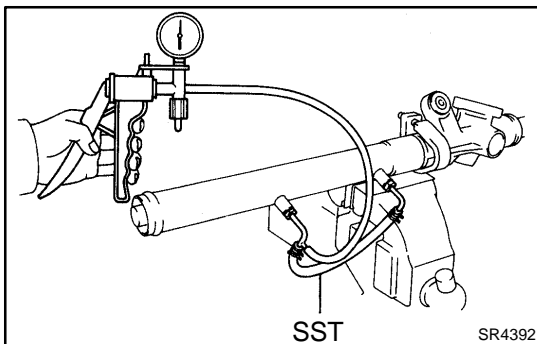

6. AIR TIGHTNESS TEST

- (a) Install SST to the rack housing.
SST 09631-12071

NOTICE:

Do not install union seats.

- (b) Apply 53.3 kPa (400 mmHg, 15.75 in.Hg) of vacuum for about 30 seconds.
 - (c) Check that there is no change in the vacuum.
- If there is change in the vacuum, check the installation of the oil seals.

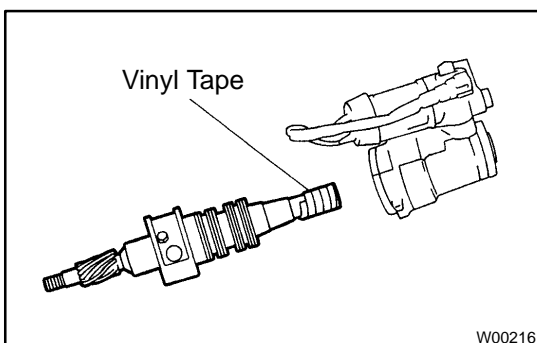

7. INSTALL CONTROL VALVE ASSEMBLY

- (a) Coat the teflon rings with power steering fluid.
- (b) To prevent oil seal lip damage, wind vinyl tape on the serrated part of the control valve shaft.
- (c) Install the valve assembly into the valve housing.

NOTICE:

Be careful not to damage the teflon rings and oil seal.

8. INSTALL CONTROL VALVE HOUSING WITH CONTROL VALVE ASSEMBLY

- (a) Coat a new O-ring with power steering fluid, and install it to the housing.
- (b) Using a hexagon wrench (6 mm), torque the 2 bolts.
Torque: 18 N·m (185 kgf-cm, 13 ft-lbf)

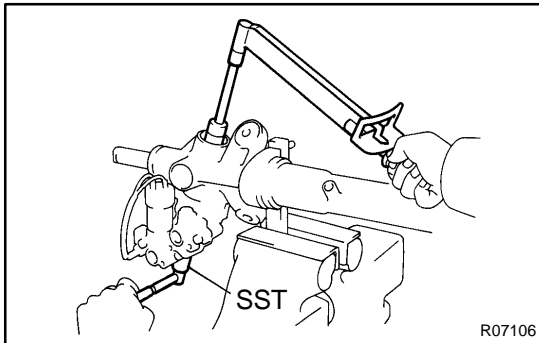
**9. INSTALL BEARING, SPACER AND SELF-LOCKING NUT**

Using SST to stop the control valve shaft rotating, torque a new nut.

SST 09616-00010

Torque: 39 N·m (400 kgf-cm, 29 ft-lbf)

10. INSTALL RACK HOUSING CAP

- (a) Apply sealant to 2 or 3 threads of the cap.

Sealant:

Part No. 08833-00080, THREE BOND 1344, LOCTITE 242 or equivalent

- (b) Torque the cap.

Torque: 69 N·m (700 kgf-cm, 50 ft-lbf)

11. INSTALL RACK GUIDE SEAT, RACK GUIDE SPRING AND RACK GUIDE SPRING CAP

- (a) Apply sealant to 2 or 3 threads of the cap.

Sealant:

Part No. 08833-00080, THREE BOND 1344, LOCTITE 242 or equivalent

- (b) Temporarily install the cap.

12. ADJUST TOTAL PRELOAD

- (a) To prevent the steering rack teeth from damaging the oil seal lip, temporarily install the RH and LH rack ends.

- (b) Using a hexagon wrench (24 mm), torque the rack guide spring cap.

Torque: 25 N·m (250 kgf-cm, 18 ft-lbf)

- (c) Using a hexagon wrench (24 mm), return the cap 12°.

- (d) Using SST, turn the control valve shaft right and left 1 or 2 times.

SST 09616-00010

- (e) Using a hexagon wrench (24 mm), loosen the cap until the rack guide spring is not functioning.

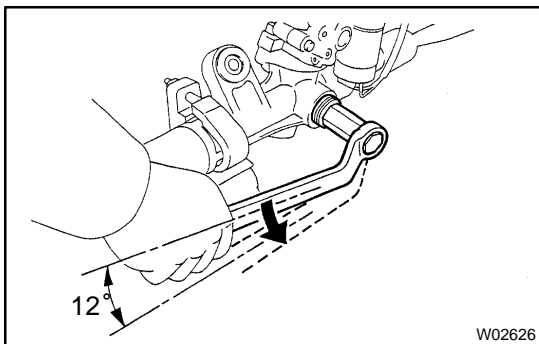

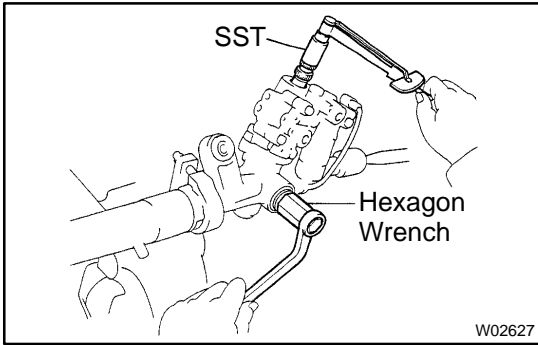

- (f) Using SST, a torque wrench and hexagon wrench (24 mm), tighten the cap until the preload is within the specification.

SST 09616-00010

Preload (turning):

1.0 - 1.9 N·m (10 - 20 kgf·cm, 8.7 - 17.4 in.-lbf)

13. INSTALL RACK GUIDE SPRING CAP LOCK NUT

- (a) Apply sealant to 2 or 3 threads of the nut.

Sealant:

Part No. 08833-00080, THREE BOND 1344, LOCTITE 242 or equivalent

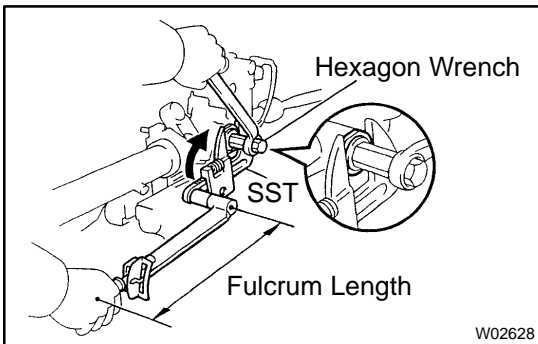

- (b) Using a hexagon wrench (24 mm) to hold the rack guide spring cap, and using SST, torque the nut.

SST 09922-10010

Torque: 50 N·m (513 kgf·cm, 37 ft-lbf)

NOTICE:

Use SST 09922-10010 in the direction shown in the illustration.

HINT:

Use a torque wrench with a fulcrum length of 345 mm (13.58 in.).

- (c) Recheck the total preload.

Preload (turning):

1.0 - 1.9 N·m (10 - 20 kgf·cm, 8.7 - 17.4 in.-lbf)

- (d) Remove the RH and LH rack ends.

14. INSTALL DUST COVER

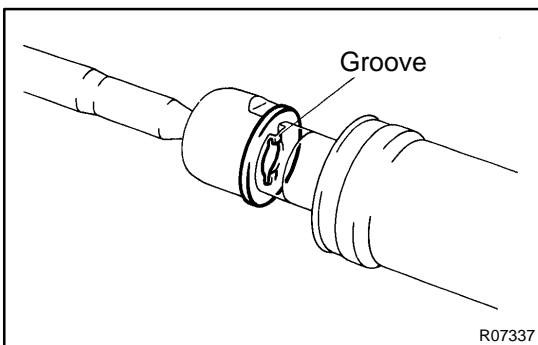

15. INSTALL RH AND LH CLAW WASHERS AND RACK ENDS

- (a) Install a new claw washer, and temporarily install the rack end.

HINT:

Align the claws of the washer with the steering rack grooves.

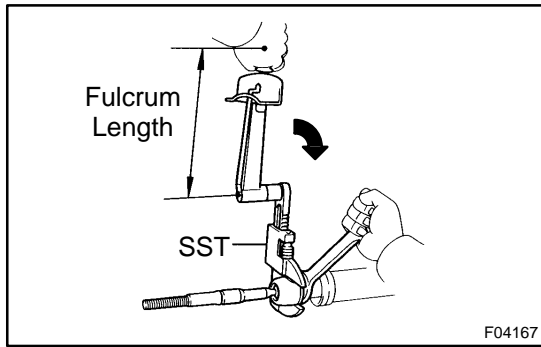

- (b) Using a spanner (22 mm) to hold the steering rack steady, and using SST, torque the rack end.
 SST 09922-10010
Torque: 77 N·m (782 kgf·cm, 57 ft·lbf)

NOTICE:

Use SST 09922-10010 in the direction shown in the illustration.

HINT:

Use a torque wrench with a fulcrum length of 380 mm (14.96 in.).

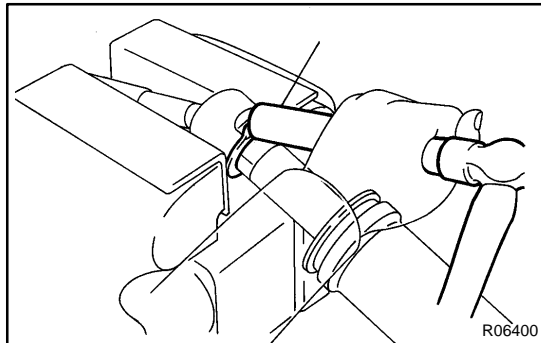

- (c) Using a brass bar and a hammer, stake the washer.

NOTICE:

Avoid any impact to the rack.

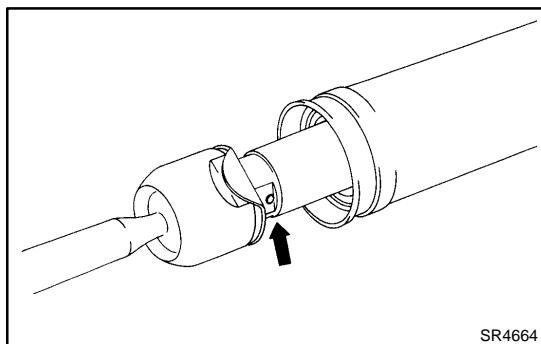

16. INSTALL RH AND LH RACK BOOTS, CLAMPS AND CLIPS

- (a) Make sure that the steering rack hole is not clogged with grease.

HINT:

If the hole is clogged, the pressure inside the boot will change after it is assembled and the steering wheel turned.

- (b) Install the boot.

NOTICE:

Be careful not to damage or twist the boot.

- (c) Install the clamp and clip to the boot.

HINT:

When the rack guide spring cap is toward you, install the clip and clamp in the positions shown in the illustration.

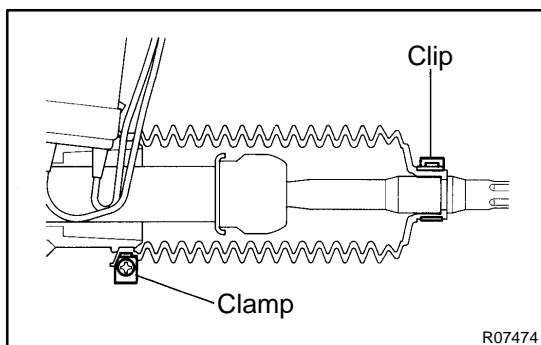

17. INSTALL RH AND LH TIE ROD ENDS AND LOCK NUTS

- (a) Screw the lock nut and tie rod end onto the rack end until the matchmarks are aligned.

- (b) After adjusting toe-in, torque the nut (See page [SA-2](#)).

Torque: 56 N·m (570 kgf·cm, 41 ft·lbf)

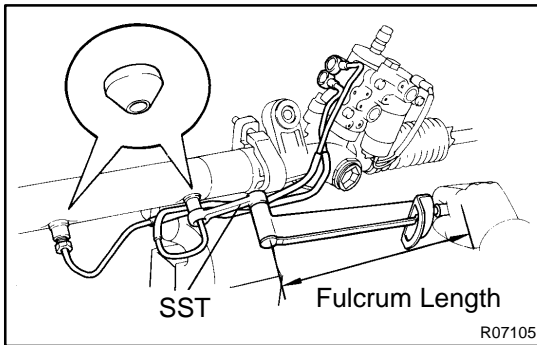
**18. INSTALL 2 TURN PRESSURE TUBES**

- (a) Install the union seat.
- (b) Using SST, install the tube.

SST 09633-00020

Torque: 24 N·m (243 kgf-cm, 18 ft-lbf)**HINT:**

- ◆ Use a torque wrench with a fulcrum length of 300 mm (11.81 in.).
- ◆ This torque value is effective in case that SST is parallel to a torque wrench.

- (c) Torque the union bolt over 2 new gaskets.

Torque: 34 N·m (350 kgf-cm, 25 ft-lbf)

INSTALLATION

1. INSTALL PS GEAR ASSEMBLY

- (a) Temporarily install the 2 bolts and nuts.
- (b) After installing the rack housing bracket and grommet, torque the 2 bolts and nuts.
Torque: 75 N·m (770 kgf·cm, 55 ft·lbf)

2. INSTALL RACK HOUSING BRACKET AND GROMMET

Torque the 2 bolts and nuts.

Torque: 75 N·m (770 kgf·cm, 55 ft·lbf)

3. CONNECT PPS SOLENOID CONNECTOR

4. CONNECT PRESSURE FEED TUBE

Torque the union bolt over a new gasket.

Torque: 49 N·m (500 kgf·cm, 36 ft·lbf)

5. CONNECT RETURN TUBE

Torque the union bolt over 2 new gaskets.

Torque: 49 N·m (500 kgf·cm, 36 ft·lbf)

6. CONNECT RH AND LH TIE ROD ENDS (See page [SA-17](#))

7. CONNECT INTERMEDIATE SHAFT (See page [SR-21](#))

8. INSTALL FR SUSPENSION MEMBER PROTECTOR

Tighten the 4 bolts.

9. INSTALL ENGINE UNDER COVER

Install the 10 bolts.

10. POSITION FRONT WHEELS FACING STRAIGHT AHEAD

HINT:

Do it with the front of the vehicle jacked up.

11. CENTER SPIRAL CABLE (See page [SR-21](#))

12. INSTALL STEERING WHEEL

- (a) Align the matchmarks on the wheel and steering column main shaft.
- (b) Temporarily tighten the wheel set nut.
- (c) Connect the connector.

13. BLEED POWER STEERING SYSTEM (See page [SR-3](#))

14. CHECK STEERING WHEEL CENTER POINT

15. TORQUE STEERING WHEEL SET NUT

Torque: 35 N·m (360 kgf·cm, 26 ft·lbf)

16. INSTALL STEERING WHEEL PAD (See page [SR-21](#))

17. CHECK FRONT WHEEL ALIGNMENT (See page [SA-2](#))

PROGRESSIVE POWER STEERING (PPS) LOCATION

SR14F-01

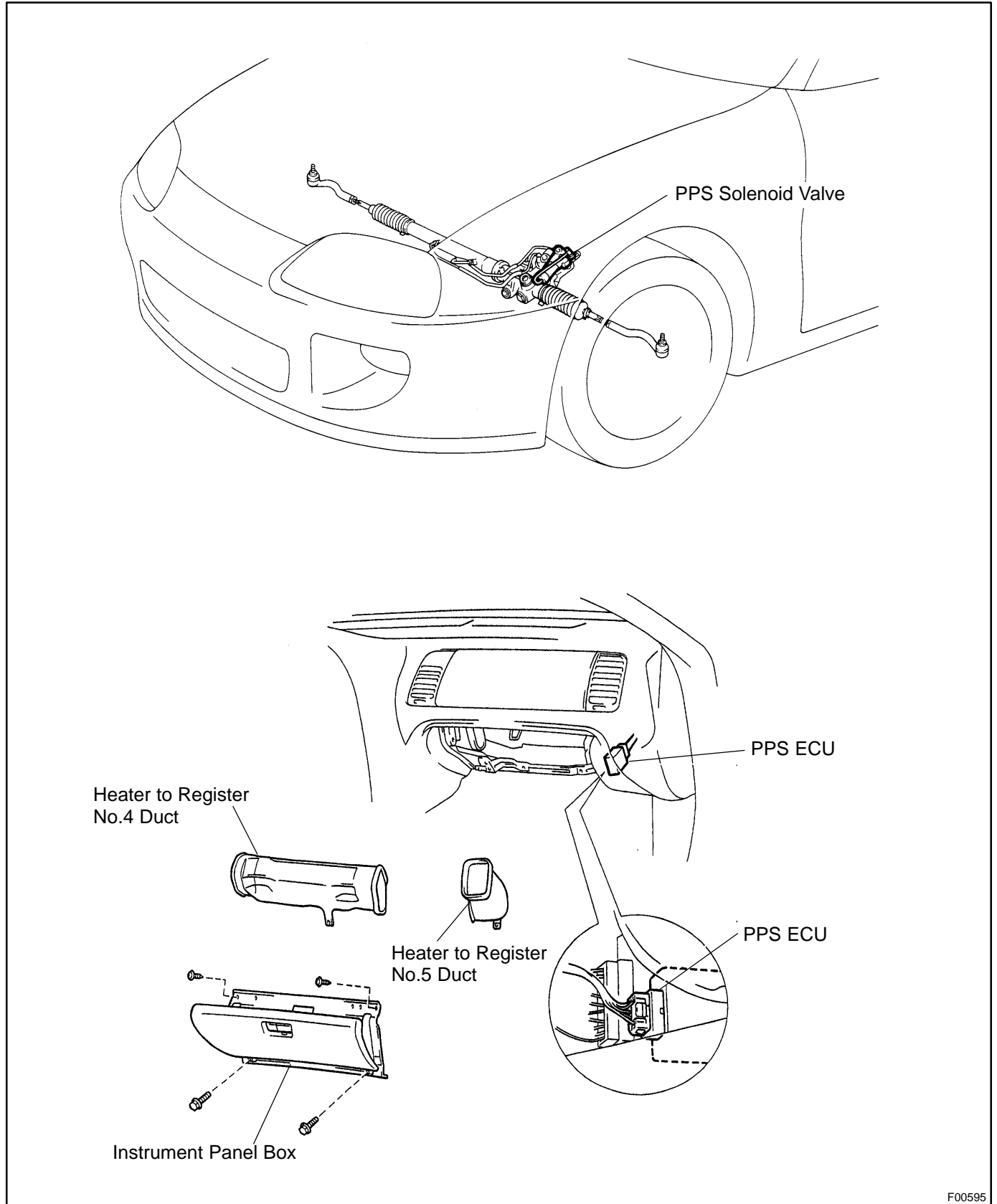

F00595

Wire Harness Side:

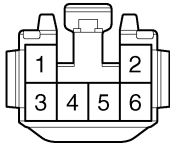

F03098

INSPECTION

1. **INSPECT ECU-IG FUSE (Instrument panel J/B)**
2. **INSPECT PPS ECU CIRCUIT**
 - (a) Disconnect the PPS ECU connector.
 - (b) Inspect the connector on wire harness side, as shown in the illustration.

Tester connection	Condition	Specified condition
4 - Body ground	Ignition switch ON	Battery positive voltage
6 - Body ground	Ignition switch ON	Continuity
*5 - 6	Ignition switch ON. Spin the rear wheel on one side with jacking or lifting UP.	0 → 5 or more → 0

If the circuit is not as specified, check and replace the wire harness.

*If the circuit is not as specified, inspect the speed sensor.

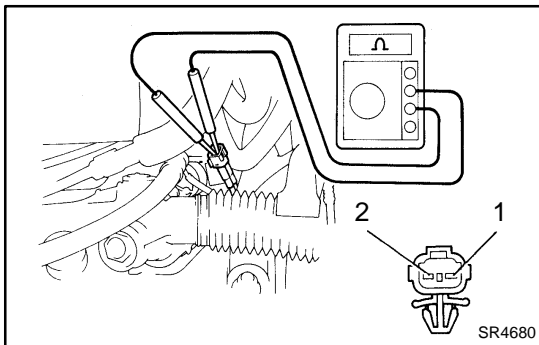

SR4680

3. **INSPECT PPS SOLENOID VALVE**

- (a) Disconnect the PPS solenoid connector.
- (b) Measure the resistance between the terminals of the solenoid 1 and 2.

Resistance: 6 - 11 Ω

If it is not as specified, replace the pressure control valve with the solenoid valve.

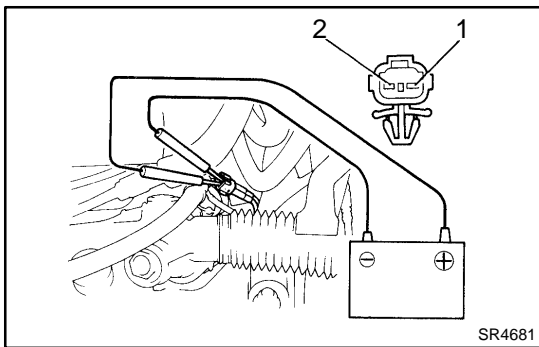

SR4681

- (c) Check the PPS solenoid operation.
 - (1) Connect the battery positive terminal to the solenoid terminal 1.
 - (2) Connect the battery negative terminal to the solenoid terminal 2.
 - (3) Check that the solenoid makes a "clicks" sound.

If it is faulty, replace the pressure control valve with the solenoid valve.

NOTICE:

- ◆ Do not apply voltage for more than 30 seconds to avoid burning out the solenoid.
- ◆ If repeating this step, wait until the solenoid cools down enough that it can be touched by hand.

- (d) Connect the PPS solenoid connector.

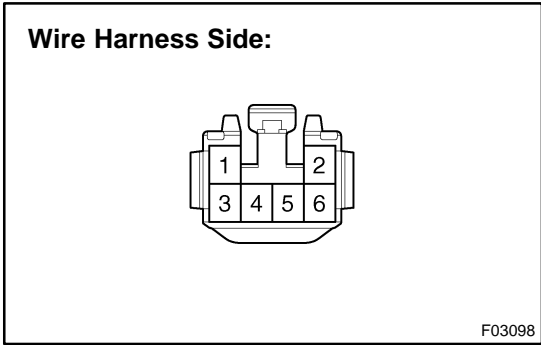

- (e) Inspect the PPS solenoid valve circuit.
 - (1) Disconnect the PPS ECU connector.
 - (2) Check continuity between the terminals of the connector on wire harness side, as shown in the illustration.

Tester connection	Specified condition
1 - 6	No continuity
2 - 6	No continuity

If it is not as specified, repair or replace wire harness or connector.

- (3) Connect the PPS ECU connector.

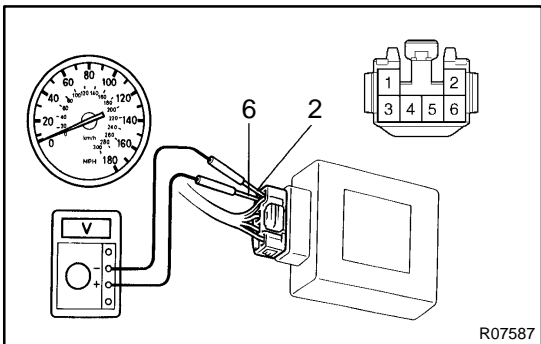

4. INSPECT PPS ECU

- (a) Jack up the vehicle and support it on stands.
- (b) Start the engine.
- (c) Measure the voltage of ECU.
 - (1) Using a voltmeter, measure the voltage between ECU terminals 2 and 6 while the engine is idling.

Standard voltage: 0.15 - 0.20 V

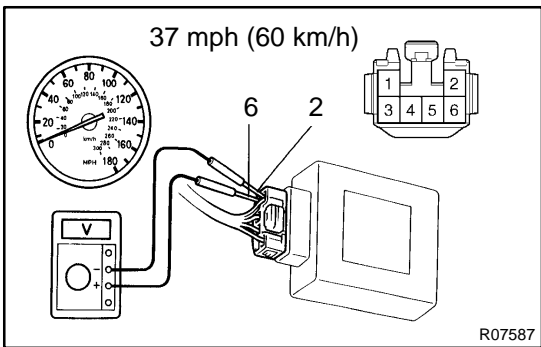

- (2) Place the transmission in gear and while running at about 62 mph (100 km/h), measure the voltage between ECU terminals 2 and 6.

Standard voltage:
2JZ-GE: 0.06 - 0.17 v
2JZ-GTE: 0.07 - 0.17 v

If no voltage, try another ECU for SUPRA.

- (d) Lower the vehicle.